

Errata

Title & Document Type: 54110D Digitizing Oscilloscope Service Manual

Manual Part Number: 54110-90902

Revision Date: October 1985

HP References in this Manual

This manual may contain references to HP or Hewlett-Packard. Please note that Hewlett-Packard's former test and measurement, semiconductor products and chemical analysis businesses are now part of Agilent Technologies. We have made no changes to this manual copy. The HP XXXX referred to in this document is now the Agilent XXXX. For example, model number HP8648A is now model number Agilent 8648A.

About this Manual

We've added this manual to the Agilent website in an effort to help you support your product. This manual provides the best information we could find. It may be incomplete or contain dated information, and the scan quality may not be ideal. If we find a better copy in the future, we will add it to the Agilent website.

Support for Your Product

Agilent no longer sells or supports this product. You will find any other available product information on the Agilent Test & Measurement website:

www.tm.agilent.com

Search for the model number of this product, and the resulting product page will guide you to any available information. Our service centers may be able to perform calibration if no repair parts are needed, but no other support from Agilent is available.



SERVICE MANUAL

MODEL 54110D DIGITIZING OSCILLOSCOPE

SERIAL NUMBERS

This manual applies directly to instruments
prefixed with serial number:

54110D = 2529A

For additional information about serial numbers see
INSTRUMENTS COVERED BY THIS MANUAL
in section I.

© COPYRIGHT HEWLETT-PACKARD COMPANY/COLORADO SPRINGS DIVISION 1985
1900 GARDEN OF THE GODS ROAD, COLORADO SPRINGS, COLORADO, U.S.A.

ALL RIGHTS RESERVED

Printed in U.S.A. October 1985

Manual Part Number 54110-90902
Microfiche Part Number 54110-90802

MANUAL CHANGES

MANUAL IDENTIFICATION

Model Number: 54110D
 Date Printed: OCTOBER 1985
 Part Number: 54110-90902

This supplement contains important information for correcting manual errors and for adapting the manual to instruments containing improvements made after the printing of the manual.

To use this supplement:

- Make all ERRATA corrections.
- Make all appropriate serial number related changes indicated in the tables.

Serial Prefix or Number	Make Manual Changes	Serial Prefix or Number	Make Manual Changes
2615A	1		
2633A	1,2		
2710A	1,2,3		
2727A	1,2,3,4		

► NEW ITEM

ERRATA

Insert X-Ray Radiation Notice and X-Ray License in manual just inside the binding's front cover.

Page 4-4, Table 4-2. Replaceable Parts, "EXCHANGE ASSEMBLIES"
 Delete: "A1 H" and Mfr Part No. 54110-6950"

Page 4-4, Table 4-2. Replaceable Parts,
 Add: MP56 HP and Mfr Part No. 5061-9448, CD 3, Qty 1, Cover - Bottom.

NOTE

Manual change supplements are revised as often as necessary to keep manuals as current and accurate as possible. Hewlett-Packard recommends that you periodically request the latest edition of this supplement. Free copies are available from all HP offices. When requesting copies quote the manual identification information from your supplement, or the model number and print date from the title page of the manual.

ERRATA (CONT'D)

Page 4-5, Table 4-2. Replaceable Parts,
Change: E1 HP and Mfr Part No. to 54100-67602

Page 4-5, Table 4-2. Replaceable Parts,
Add: W14 HP and Mfr Part No. 8120-4600, CD 8, Qty 0, Pwr Cord (Option 917), Mfr Code 28480

Page 4-6, Table 4-2. Replaceable Parts,
Change: W2 HP and Mfr Part No. to 54100-61602, CD 6

►Page 3-42, Adjustments

If your instrument contains a recently manufactured Timebase board (A4), adjustment capacitor A4C102 may or may not be installed on the board. Several electrical components on the board were replaced by components with tighter electrical specifications, eliminating the need for the adjustment capacitor. Visually inspect the Timebase board's bottom left corner to see if it contains the adjustable capacitor C102. This is the only adjustable capacitor on the board. If the capacitor is **not** installed on the Timebase board, do not perform adjustment procedure 4-20.

CHANGE 1

Page 4-4, Table 4-2 Replaceable Parts,
Change: A2 HP and Mfr Part No. to 54100-66524, CD 1
Change: *A2 HP and Mfr Part No. to 54100-69524, CD 7

CHANGE 2

Page 4-4, Table 4-2. Replaceable Parts,
Change: A10 HP and Mfr Part No. to 54110-66512, CD 9
Change: *A10 HP and Mfr Part No. to 54110-69512, CD 5

CHANGE 3

Page 4-4, Table 4-2. Replaceable Parts,
Change: A14 HP and Mfr Part No. to 54110-66511, CD 8, QT 1
Change: *A14 HP and Mfr Part No. to 54110-69511, CD 4, QT 1
Change: B1 HP and Mfr Part No. to 3160-0521, CD 3, QT 2
Change: MP46 HP and Mfr Part No. to 54110-04108, CD 9, QT 1
Add: HP and Mfr Part No. 5061-6138, CD 2, QT 8, Insert Nut - Fan
Add: HP and Mfr Part No. 0515-0435, CD 8, QT 8, Screw - Fan

►CHANGE 4

Page 4-4, Table 4-2. Replaceable Parts,
Change: A11 HP and Mfr Part No. to 54110-66513, CD 0
Change: *A11 HP and Mfr Part No. to 54110-69513, CD 6

Change: A12 HP and Mfr Part No. to 54110-66510, CD 7
Change: *A12 HP and MFR Part No. to 54110-69510, CD 3

X-RAY RADIATION NOTICE

ACHTUNG

Model 54110D

WARNING

Während des Betriebs erzeugt dieses Gerät Röntgenstrahlung. Das Gerät ist so abgeschirmt, daß die Dosisleistung weniger als 36 $\mu\text{A kg}$ (0,5 mR/h) in 5cm Abstand von der Oberfläche der Katodenstrahlröhre beträgt. Somit sind die Sicherheitsbestimmungen verschiedener Länder, u.A. der deutschen Röntgenverordnung eingehalten.

Die Stärke der Röntgenstrahlung hängt im Wesentlichen von der Bauart der Katodenstrahlröhre ab, sowie von den Spannungen, welche an dieser anliegen. Um einen sicheren Betrieb zu gewährleisten, dürfen die Einstellungen der Niederspannungs- und des Hochspannungsnetzteils nur nach der Anleitung in Kapitel V des Handbuches vorgenommen werden.

Die Katodenstrahlröhre darf nur durch die gleiche Type ersetzt werden. (Siehe Kapitel VI für HP - Ersatzteile).

Das Gerät ist in Deutschland zugelassen unter

der Nummer: BW/218/86/Roe

When operating, this instrument emits x-rays, however, it is well shielded and meets safety and health requirements of various countries, such as the X-ray Radiation Act of Germany

Radiation emitted by this instrument is less than 0.5 mR/hr at a distance of five (5) centimeters from the surface of the cathode-ray tube. The x-ray radiation primarily depends on the characteristics of the cathode-ray tube and its associated low-voltage and high-voltage circuitry. To ensure safe operation of the instrument, adjust both the low-voltage and high-voltage power supplies as outlined in Section V of this manual (if applicable).

Replace the cathode-ray tube with an identical CRT only. Refer to Section VI for proper HP part number.

Number of German License: BW/218/86/Roe



GEWERBEAUFSICHTSAMT STUTTGART

- Zentrale Stelle für Sicherheitstechnik und Vorschriftenwesen in Baden-Württemberg -

Gewerbeaufsichtsamt - Lagerstr. 28 - Postfach 703 - 7000 Stuttgart 1

Stuttgart, den 16.01.1986

Fernsprecher

(07 11) 205 01 (Behördenzentrum)

Durchwahl 2050 - 4798

Aktenzeichen Z 5108/EP/W:
(Bitte bei Antwort angeben)

Firma
Hewlett Packard GmbH
Herrenberger Str. 110/130

7030 Böblingen

Zulassungsschein Nr. BW/218/86/R8

Gemäß § 9 der Röntgenverordnung vom 01.03.1973 (BGBl. I S. 173) wird die Zulassung der Bauart durch den Bauartzulassungsbescheid vom 16.01.1986 mit Aktenzeichen Z 5108/HP/Ws/Eh für den nachfolgend aufgeführten Störstrahlröhre bescheinigt:

Gegenstand	Digital-Oszilloskop
Firmenbezeichnung	: HP Typ 54110D
Bildröhre	: Sony Typ M23 JHU 15K
Hersteller	: Hewlett-Packard 1900 Garden of the Gods Road Colorado Springs Colorado 80907, USA
Betriebsbedingungen	: Hochspannung: max. 22,3 kV Strahlstrom: max. 0,4 mA
Zulassungskennzeichen	: BW/218/86/R8

Die Bauartzulassung ist befristet bis 16.01.1996.

Für den Strahlenschutz wesentliche Merkmale

1. Die Art und Qualität der Bildröhre,
2. die der Hochspannungserzeugung und -stabilisierung dienenden Bauelemente.

Auflagen:

1. Die Geräte sind bezüglich der für den Strahlenschutz wesentlichen Merkmale entsprechend den vorgestellten und geprüften Mustern und Antragsunterlagen herzustellen.
2. Die Geräte sind einer Stückprüfung daraufhin zu unterziehen, ob sie bezüglich der für den Strahlenschutz wesentlichen Merkmale der Bauartzulassung entsprechen.

Die Prüfung muß umfassen:

- a) Kontrolle der Hochspannung an jedem einzelnen Gerät,
 - b) Messung und Dosisleistung nach Festlegung im Bauartzulassungsbescheid.
3. Die Herstellung und die Stückprüfung sind durch den von der Zulassungsbehörde bestimmten Sachverständigen überwachen zu lassen.
 4. Die Geräte sind deutlich sichtbar und dauerhaft mit dem Kennzeichen

BW/218/86/R3

zu versehen sowie mit einem Hinweis folgenden Mindestinhalts:

"Die in diesem Gerät entstehende Röntgenstrahlung ist ausreichend abgeschirmt.
Beschleunigungsspannung maximal 22,3 kV."

Hinweis für den Benutzer des Geräts:

Unsachgemäße Eingriffe, insbesondere Verändern der Hochspannung oder Auswechseln der Bildröhre können dazu führen, daß Röntgenstrahlung in erheblicher Stärke auftritt. Ein so verändertes Gerät entspricht nicht mehr dieser Zulassung und darf infolgedessen nicht mehr betrieben werden.

Reutter

Reutter



Dieses Gerät wurde nach den Auflagen der Zulassungsbehörde einer Stückprüfung unterzogen und entspricht in den für den Strahlenschutz wesentlichen Merkmalen der Bauartzulassung. Die Beschleunigungsspannung beträgt maximal 22,3 kV.

Hewlett-Packard
1900 Garden of the Gods Road
Colorado Springs
Colorado 80907, USA

MANUAL CHANGES

MANUAL IDENTIFICATION

Model Number: 54110D
Date Printed: OCTOBER 1985
Part Number: 54110-90902

This supplement contains important information for correcting manual errors and for adapting the manual to instruments containing improvements made after the printing of the manual.

To use this supplement:
Make all ERRATA corrections.
Make all appropriate serial number related changes indicated in the tables.

Serial Prefix or Number	Make Manual Changes	Serial Prefix or Number	Make Manual Changes
ALL	ERRATA		

► NEW ITEM

► ERRATA

Page 4-5, Table 4-2. Replaceable Parts,
Change: E1 HP and Mfr Part No. to 54100-67602

NOTE

Manual change supplements are revised as often as necessary to keep manuals as current and accurate as possible. Hewlett-Packard recommends that you periodically request the latest edition of this supplement. Free copies are available from all HP offices. When requesting copies quote the manual identification information from your supplement, or the model number and print date from the title page of the manual.

25 OCTOBER 1985
1 OF 1

 HEWLETT
PACKARD

SAFETY

This product has been designed and tested according to International Safety Requirements. To ensure safe operation and to keep the product safe, the information, cautions, and warnings in this manual, must be heeded. Refer to Section I and the Safety Summary for general safety considerations applicable to this product.

This apparatus has been designed and tested in accordance with IEC publication 348, safety requirements for electronic measuring apparatus, and has been supplied in a safe condition. This manual contains some information and warnings which have to be followed by the user to ensure safe operation and to retain the apparatus in safe condition.

CERTIFICATION

Hewlett-Packard Company certifies that this product met its published specifications at the time of shipment from the factory. Hewlett-Packard further certifies that its calibration measurements are traceable to the United States National Bureau of Standards, to the extent allowed by the Bureau's calibration facility, and to the calibration facilities of other International Standards Organization members.

WARRANTY

This Hewlett-Packard product is warranted against defects in material and workmanship for a period of one year from date of shipment. During the warranty period, Hewlett-Packard Company will, at its option, either repair or replace products which prove to be defective.

For warranty service or repair, this product must be returned to a service facility designated by HP. However, warranty service for products installed by HP and certain other products designated by HP will be performed at Buyer's facility at no charge within the HP service travel area. Outside HP service travel areas, warranty service will be performed at Buyer's facility only upon HP's prior agreement and Buyer shall pay HP's round trip travel expenses.

For products returned to HP for warranty service, Buyer shall prepay shipping charges to HP and HP shall pay shipping charges to return the product to Buyer. However, Buyer shall pay all shipping charges, duties, and taxes for products returned to HP from another country.

LIMITATION OF WARRANTY

The foregoing warranty shall not apply to defects resulting from improper or inadequate maintenance by Buyer, Buyer-supplied software or interfacing, unauthorized modification or misuse, operation outside of the environmental specifications for the product, or improper site preparation or maintenance.

NO OTHER WARRANTY IS EXPRESSED OR IMPLIED. HP SPECIFICALLY DISCLAIMS THE IMPLIED WARRANTIES OR MERCHANTABILITY AND FITNESS FOR A PARTICULAR PURPOSE.

EXCLUSIVE REMEDIES

THE REMEDIES PROVIDED HEREIN ARE BUYER'S SOLE AND EXCLUSIVE REMEDIES. HP SHALL NOT BE LIABLE FOR ANY DIRECT, INDIRECT, SPECIAL INCIDENTAL, OR CONSEQUENTIAL DAMAGES, WHETHER BASED ON CONTRACT, TORT, OR ANY OTHER LEGAL THEORY.

ASSISTANCE

Product maintenance agreements and other customer assistance agreements are available for Hewlett-Packard products.

For any assistance, contact your nearest Hewlett-Packard Sales and Service Office. Addresses are provided at the back of this manual.

SCWA984

SAFETY CONSIDERATIONS

GENERAL - This is a Safety Class I instrument (provided with terminal for protective earthing)

OPERATION - BEFORE APPLYING POWER verify that the power transformer primary is matched to the available line voltage, the correct fuse is installed, and Safety Precautions are taken (see the following warnings). In addition, note the instrument's external markings which are described under "Safety Symbols"

WARNING

- o Servicing instructions are for use by service-trained personnel. To avoid dangerous electric shock, do not perform any servicing unless qualified to do so.
- o BEFORE SWITCHING ON THE INSTRUMENT, the protective earth terminal of the instrument must be connected to the protective conductor of the (mains) powercord. The mains plug shall only be inserted in a socket outlet provided with a protective earth contact. The protective action must not be negated by the use of an extension cord (power cable) without a protective conductor (grounding). Grounding one conductor of a two-conductor outlet is not sufficient protection.
- o If this instrument is to be energized via an auto-transformer (for voltage reduction) make sure the common terminal is connected to the earth terminal of the power source.
- o Any interruption of the protective (grounding) conductor (inside or outside the instrument) or disconnecting the protective earth terminal will cause a potential shock hazard that could result in personal injury.
- o Whenever it is likely that the protection has been impaired, the instrument must be made inoperative and be secured against any unintended operation.
- o Only fuses with the required rated current, voltage, and specified type (normal blow, time delay, etc.) should be used. Do not use repaired fuses or short circuited fuseholders. To do so could cause a shock or fire hazard.
- o Do not operate the instrument in the presence of flammable gasses or fumes. Operation of any electrical instrument in such an environment constitutes a definite safety hazard.
- o Do not install substitute parts or perform any unauthorized modification to the instrument.
- o Adjustments described in the manual are performed with power supplied to the instrument while protective covers are removed. Energy available at many points may, if contacted, result in personal injury.
- o Any adjustment, maintenance, and repair of the opened instrument under voltage should be avoided as much as possible, and when inevitable, should be carried out only by a skilled person who is aware of the hazard involved.
- o Capacitors inside the instrument may still be charged even if the instrument has been disconnected from its source of supply.

SAFETY SYMBOLS



Instruction manual symbol. The product will be marked with this symbol when it is necessary for the user to refer to the instruction manual in order to protect against damage to the product.



Indicates hazardous voltages.



Earth terminal (sometimes used in manual to indicate circuit common connected to grounded chassis).

WARNING

The WARNING sign denotes a hazard. It calls attention to a procedure, practice, or the like, which, if not correctly performed or adhered to, could result in personal injury. Do not proceed beyond a WARNING sign until the indicated conditions are fully understood and met.

CAUTION

The CAUTION sign denotes a hazard. It calls attention to an operating procedure, practice, or the like, which, if not correctly performed or adhered to, could result in damage to or destruction of part or all of the product. Do not proceed beyond a CAUTION sign until the indicated conditions are fully understood or met.

TABLE OF CONTENTS

Section	Page
I. GENERAL INFORMATION	1-1
Introduction	1-1
Specifications	1-1
Safety Considerations	1-1
Instruments Covered By Manual	1-11
Description	1-11
Line Voltage Selection	1-11
Grounding Requirements	1-12
Options	1-14
Accessories Supplied	1-14
Recommended Test Equipment	1-14
Packaging For Shipment	1-14
II. PERFORMANCE TESTS	2-1
Introduction	2-1
Performance Test Equipment Required	2-1
Test Record	2-2
Calibration Cycle	2-2
Performance Test Procedures	2-2
Vertical Accuracy Test	2-3
Bandwidth Test	2-4
Step Response (Risetime) Test	2-6
Time Interval Accuracy Test	2-7
Trigger Sensitivity Test	2-9
Aperture Jitter Test	2-11
III. ADJUSTMENTS	3-1
Introduction	3-1
Calibration Interval	3-1
Adjustment Test Equipment Required	3-1
Adjustment Procedures	
Power Supply Adjustments	3-3
DC Offset Adjustment	3-6
Input and Output Offset Null Adjustment	3-8
Sampler Bias Adjustment	3-10
Flatness and Sampling Efficiency Adjustments	3-12
Offset Calibration Adjustment	3-16
Gain Adjustments	3-18

TABLE OF CONTENTS (Continued)

Section	Page
Adjustment Procedures (Continued)	
Sampling Board Trigger Adjustments	3-20
HF Gain (Pulse Flatness) Adjustment	3-22
Main Trigger Board Calibration Adjustments	3-24
Fine Interpolator Calibration	3-26
Trigger Qualifier Calibration Adjustments	3-32
Startable Oscillator Adjustment	3-35
Filter Time Offset Adjustment	3-36
Last Event Holdoff Adjustment	3-38
Delay Offset Adjustment	3-40
81.669 MHz Master Oscillator Overtone Tuning	3-42
CRT Module Adjustments	3-44
IV. REPLACEABLE PARTS	4-1
Introduction	4-1
Abbreviations	4-1
Replaceable Parts List	4-1
Ordering Information	4-2
Direct Mail Order System	4-2
V. MANUAL CHANGES	5-1
Introduction	5-1
VI. SERVICE	6-1
Introduction	6-1
Service Test Equipment Required	6-1
Safety Considerations	6-2
Assembly Removal And Replacement Procedures	
Card Cage PC Boards	6-4
AC Power Supply PC Board (A11)	6-6
Analog Power Supply PC Board (A12)	6-9
Digital Power Supply PC Board (A13)	6-10
CRT Bezel	6-12
Front Panel	6-14
Front Panel Control PC Board (A15)	6-14
CRT Control PC Board (A18)	6-14
CRT Display Module (A19)	6-21

TABLE OF CONTENTS (Continued)

Section	Page
Assembly Removal And Replacement Procedures (Continued)	
POD Connectors	6-24
Fans	6-26
Display PC Board (A10)	6-27
Mother Board (A14)	6-29
6A - SERVICE MENUS/KEYS	6A-1
Introduction	6A-1
Service Menus	6A-1
Test Menu	6A-2
Repeat Loop/Run From Loop Key	6A-2
Interface Tests Key	6A-3
Start/Stop Key	6A-4
Display Errors Key	6A-4
Display Configuration Key	6A-4
CRT Setup Menu	6A-5
Confidence Test Key	6A-5
Pattern Off Key	6A-5
Light Output Key	6A-6
Color Purity Key	6A-6
6B - SELF-TESTS/TROUBLESHOOTING	6B-1
Introduction	6B-1
Failure Indications	6B-1
Failure Verification	6B-1
Troubleshooting Sequence	6B-1
Internal Diagnostics	6B-3
Performing Self-Test	6B-3
Keyboard (Interface 11) Test	6B-4
2-Key Power-up (Hard Reset)	6B-4
Troubleshooting with No Display	6B-5
Troubleshooting The Power Supplies	6B-5
Power Supply Failure Indications	6B-5
Excessive Loading Of Power Supplies	6B-6
CRT Display Module Failure Isolation	6B-7
Display Board Failure Verification	6B-12
Manual Signature Analysis (DSA)	6B-13
Troubleshooting with the Display Operating	6B-15
Self-Test Failure Codes	6B-16
Troubleshooting the Analog Portion of the 54110D	6B-16
Board Swap	6B-17
Signal Exchange (Chan 1 and 2)	6B-17
Waveform Comparison	6B-18
POD/Probe Troubleshooting	6B-24

LIST OF TABLES

Table	Title	Page
1-1	Specifications	1-2
1-2	Supplemental Characteristics	1-6
1-3	AC Power Cables	1-13
2-1	Recommended Performance Test Equipment	2-1
2-2	Performance Test Record	2-13
3-1	Recommended Calibration Test Equipment	3-2
4-1	Reference Designators and Abbreviations	4-3
4-2	Replaceable Parts List	4-4
6-1	Recommended Service Test Equipment	6-3
6B-1	Signatures for Loop Failures	6B-14

LIST OF ILLUSTRATIONS

Figure	Title	Page
1-1	Power Module	1-12
3-1	Sampling Efficiency Adjusted Correctly	3-15
3-2	Leading edge with area of discontinuity (no data present)	3-27
3-3	Area of discontinuity is centered vertically	3-28
3-4	Area of discontinuity is centered and expanded	3-29
3-5	Waveform when adjustment is correct	3-30
3-6	Close adjustment but not correct (note small "S" shape)	3-31
3-7	CRT Module Adjustment Flow Diagram	3-45
3-8	PIN AMP Adjustment	3-46
3-9	PIN PHASE Adjustment	3-47
3-10	Purity Magnet Centering	3-49
3-11	Purity Magnet Adjustment Raster	3-50
3-12	Landing And Purity Adjustment Guide	3-51
3-13	Static Convergence	3-52
3-14	Y BOW Adjustment	3-53
3-15	Y BOW CROSS Adjustment	3-53
3-16	V.STAT TOP Adjustment	3-54
3-17	V.STAT BOTTOM Adjustment	3-54
3-18	H.AMP Adjustment	3-55
3-19	H.TILT Adjustment	3-55

LIST OF ILLUSTRATIONS (Continued)

Figure	Title	Page
6-1	PC Card Retaining Bracket Removal	6-5
6-2	AC Power Supply Side Attaching Screws	6-7
6-3	AC Power Supply Rear Attaching Screws	6-8
6-4	Analog/Digital Power Supply Retaining Screws	6-11
6-5	CRT Bezel Removal Pushing Locations	6-13
6-6	Top Front Panel Attaching Screws	6-16
6-7	Bottom Front Panel Attaching Screws	6-17
6-8	Left Side Front Panel Attaching Screws	6-18
6-9	Right Side Front Panel Attaching Screws	6-19
6-10	Front Panel to Deck Attaching Nuts	6-20
6-11	Front CRT Module Attaching Screws	6-22
6-12	Rear CRT Module Attaching Screws	6-23
6-13	POD Connector Attaching Screws	6-25
6-14	Fan Housing Attaching Screws	6-26
6-15	Display PC Board Attaching Screws	6-28
6-16	Mother Board Attaching Screws	6-30
6B-1	Troubleshooting Sequence Flow Chart	6B-2
6B-2	CRT Display Module Input Connectors	6B-8
6B-3	Correct Vertical Sync Waveform	6B-9
6B-4	Correct Horizontal Sync Waveform	6B-9
6B-5	Correct Red Video Waveform	6B-10
6B-6	Correct Green Video Waveform	6B-11
6B-7	Correct Blue Video Waveform	6B-11
6B-8	54110D Cable Location Diagram	6B-19
6B-9	Waveform on the A3 MCLK (Master Clock) cables	6B-20
6B-10	Waveform on the A3 CAL (CAL signal) cables	6B-21
6B-11	Waveform at the A4/A6 IF out cables	6B-22
6B-12	Waveform at the A4/A6 TCLK (Trigger Clock) cables	6B-23

PRINTING HISTORY

New editions are complete revisions of the manual. Update packages, which are issued between editions, contain additional and replacement pages to be merged in the manual by the Customer Engineer. The date on the title page changes only when a new edition is published. When an edition is revised, all the prior updates to the edition are incorporated.

First Edition October 1985

LIST OF EFFECTIVE PAGES

The List of Effective Pages gives the date of the current edition of any pages changed in updates to that edition. Within the manual, any page changed since the last edition is indicated by printing the date the changes occurred on the bottom on the page.

All pages are original first edition



SECTION I

GENERAL INFORMATION

1-1. INTRODUCTION

This Service Manual contains information necessary to test, adjust, and service the Hewlett-Packard 54110D Digitizing Oscilloscope. This manual is divided into 6 sections as follows:

- I - General Information
- II - Performance Tests
- III - Adjustments
- IV - Replaceable Parts
- V - Manual Changes
- VI - Service

Information for operating, programming, and interfacing the Model 54110D is contained in the 54110D Operating and Programming Manual supplied with each instrument.

The General Information Section includes a description of the 54110D Digitizing Oscilloscope, its specifications, options, available accessories, and general installation instructions

Also listed on the title page of this manual is a Microfiche part number. This number can be used to order 4 X 6 inch microfilm transparencies of the manual. Each microfiche contains up to 96 photo-duplicates of the manual pages. The microfiche package also includes the latest Manual Changes supplement as well as pertinent Service Notes.

1-2. SPECIFICATIONS

Table 1-1 lists the specifications for the Model 54110D. These specifications include the performance standards against which the oscilloscope is tested. Also included is Table 1-2, which lists supplemental characteristics. Supplemental characteristics are not specifications but are typical characteristics included as additional information for the user.

1-3. SAFETY CONSIDERATIONS

Safety information relevant to the service procedure being described is provided in the appropriate sections of this manual. The Model 54110D and this manual should be reviewed for safety markings and instructions before work is begun.

Table 1-1. Specifications

VERTICAL (Voltage)

Bandwidth (-3dB):¹

with HP 54002A: dc to 1 GHz
with HP 54001A: dc to 700 Mhz
with HP 54003A: dc to 300 Mhz

Transition Time (10% to 90%):¹

with HP 54002A: ≤ 350 ps
with HP 54001A: ≤ 450 ps
with HP 54003A: ≤ 1.2 ns

Deflection Factor (full-scale = 8 divisions):¹

with HP 54002A: 10 mV/div to 1 V/div in 1-2-5 steps
with HP 54001A: 100 mV/div to 10 V/div in 1-2-5 steps
with HP 54003A: 100 mV/div to 10 V/div in 1-2-5 steps

DC Accuracy, Single Voltage Marker:¹

with HP 54002A: $\pm 3\%$ of full-scale $\pm 2\%$ of offset²
with HP 54001A: $\pm 6\%$ of full-scale $\pm 2\%$ of offset ± 50 mV
with HP 54003A: $\pm 6\%$ of full-scale $\pm 2\%$ of offset ± 50 mV

DC Delta Voltage Accuracy (Two Markers On Same Channel):¹

with HP 54002A: $\pm 1\%$ of full-scale $\pm 3\%$ of reading²
with HP 54001A: $\pm 1\%$ of full-scale $\pm 6\%$ of reading
with HP 54003A: $\pm 1\%$ of full-scale $\pm 6\%$ of reading

DC Offset:

RANGE: ± 1.5 x full-scale (referenced to center screen)

ADJUSTMENT RESOLUTION: adjustable in steps of 0.0025 x full-scale

Dynamic Range: deflection factor and offset should be scaled so that the unmagnified signal remains within the full-scale display range.

Magnifier: expands displayed signal vertically from 1 to 16 times; adjustable in 0.5% steps.

Inputs: two inputs, configurable with HP 54000-series pods.

Table 1-1 Specifications (Continued)

HORIZONTAL (Time)			
Deflection Factor (full-scale = 10 divisions): 100 ps/div to 1 s/div			
ADJUSTMENT RESOLUTION: adjustable in 1-2-5 steps via knob and cursor keys. Adjustable to three significant figures via keypad or HP-IB command.			
Delay (Time Offset):			
PRE-TRIGGER RANGE: up to -200 ms or -10 divisions, whichever is greater.			
POST-TRIGGER RANGE: up to +1 second or +10 divisions, whichever is greater.			
ADJUSTMENT RESOLUTION: adjustable in steps of 10 ps or 10^{-6} x delay setting, whichever is greater.			
Time Base Accuracy:			
SINGLE-CHANNEL: $\leq (100 \text{ ps} \pm 2 \times 10^{-5} \times \text{delta T reading})$			
DUAL-CHANNEL: $\leq (200 \text{ ps} \pm 2 \times 10^{-5} \times \text{delta T reading})$			
TRIGGER			
Trigger Source	Vertical Channel 1 or 2		
Input Pod	HP 54002A	HP 54001A	HP 54003A ³
Trigger Level Range	$\pm 2 \times \text{full-scale}$		
Trigger Level Adjustment Resolution	$0.0025 \times \text{full-scale}$		
Trigger Sensitivity DC to 100 MHz	$0.12 \times \text{full-scale}$		
Above 100 Mhz (frequency range)	$0.24 \times \text{full-scale}$ (100 MHz to 500 MHz)	$0.24 \times \text{full-scale}$ (100 Mhz to 300 Mhz)	
Pulse width > 1 ns	$0.24 \times \text{full-scale}$		

Table 1-1. Specifications (Continued)

TRIGGER (Continued)				
Trigger Source	Trigger Input 3 or 4			
Input Pod	HP 54002A	HP 54001A	HP 54003A ³	
Trigger Level Range	±2 V	±20 V		
Trigger Level Adjustment Resolution	2 mV	20 mV		
Trigger Sensitivity DC to 100 MHz	40 mV	400 mV		
Above 100 Mhz (frequency range)	80 mV (100 MHz to 500 MHz)	800 mV (100 Mhz to 500 MHz)	800 Mv (100 MHz to (300 Mhz)	
Pulse width > 1 ns	80 mV	800 mV		
<p>RMS Jitter: $\pm(50 \text{ ps} + 5 \times 10^{-7} \times \text{delay setting})$</p> <p>Trigger Source: channel 1, channel 2, trigger 3, trigger 4. Independent trigger level settings on all sources. Edge trigger on any source. Logical pattern trigger on all sources.</p> <p>Trigger 3 and 4 Input: configurable with HP 54000-series pods.</p>				
INPUTS				
	HP 54002A 50Ω Input	HP 54001A 1 GHz Miniature Active Probe	HP 54003A 1 MΩ Input, With 10:1 Probe Attached	HP 54003A 1 MΩ Input, With 10:1 Probe Removed
Maximum Input Voltage	5 V rms	20 V peak	20 V peak	2 V peak

Table 1-1. Specifications (Continued)

INPUTS (Continued)				
	HP 54002A 50 Ω Input	HP 54001A 1 GHz Miniature Active Probe	HP 54003A 1 M Ω Input, With 10:1 Probe Attached	HP 54003A 1 M Ω Input, With 10:1 Probe Removed
Coupling	dc	dc	dc	dc
Input Capacitance (Nominal)	N/A	2 pf	8 pf	10 pf
Input Resistance (Nominal)	50 Ω	10 k Ω	1 M Ω	1 M Ω
Bandwidth * (-3dB)	dc to 1 GHz	dc to 1 GHz	dc to 300 MHz	dc to 300 MHz
Transition Time * (10% to 90%)	≤ 350 ps	≤ 350 ps	≤ 1.2 ns	≤ 1.2 ns
Division Ratio *	1:1	10:1 $\pm 3\%$	10:1 $\pm 3\%$	1:1 $\pm 1\%$

CATHODE-RAY TUBE

X-RAY EMISSION: CRT emission <0.1 mR/hr; not measurable in background noise using Victoreen Model 440RF/C.

NOTES:

1. These specifications apply over ambient temperature range of +15°C to +35°C.
2. When driven from a 50 Ω source.
3. With the 10:1 divider probe supplied with the 54003A.

* Refer to VERTICAL and TRIGGER specifications for system performance specifications.

Table 1-2. Supplemental Characteristics

DIGITIZER

Resolution: 7 bits (1 part in 128). Effective resolution can be extended up to approximately 10 bits by using magnification and averaging.

Digitizing Rate: up to 40 megasamples/second.

VERTICAL

Input Protection: a relay opens when applied voltage exceeds rated input voltage for input pod in use (see Specifications).

HORIZONTAL

Delay Between Channels: difference in delay between channels can be nulled out in 10 ps steps up to 10 ns to compensate for differences in input cables or probe length.

Reference Location: the reference point can be located at the left edge, center, or right edge of the display. The reference point is that point where the time is offset from the trigger by the delay time.

TRIGGER

Input Protection: a message appears on the display when the applied voltage exceeds rated input voltage for input pod in use (see Specifications).

Holdoff

HOLDOFF-BY-EVENTS: range of events counter is from 2 to 67 million events. Maximum counting rate is 80 MHz. An event is defined as anything that satisfies the triggering conditions selected.

HOLDOFF-BY-TIME: adjustable in 10 ns steps from 70 ns to 670 ms.

Trigger Modes

EDGE TRIGGER: on any source (see Specifications, Trigger Source).

PATTERN TRIGGER: a pattern can be specified for all sources. Each source can be specified as high, low, or don't care. Trigger can occur on the last edge to enter the specified pattern or the first edge to exit the specified pattern.

Table 1-2. Supplemental Characteristics (Continued)

Trigger Modes (Continued)

TIME QUALIFIED PATTERN TRIGGER: trigger occurs on the first edge to exit the specified pattern, only if the pattern was present for less than [greater than] the specified time. Filter time is adjustable from 10 ns to 5 seconds. Filter recovery time is ≤ 8 ns. In the "Pattern present <[time]" mode, the pattern must be present ≥ 1 ns for the trigger to respond.

STATE TRIGGER: a pattern can be specified for any three sources. Trigger can be set to occur on an edge of either polarity on the source specified as the clock (not one of the pattern sources) when the pattern is present or not present. Setup time for the pattern to be present prior to the clock edge is < 4 ns; hold time is zero.

Delayed Trigger

EVENTS-DELAYED MODE: the trigger can be armed by an edge on any source, then triggered by the n th edge on any other source.

The number of events, n , can be set from 1 to $10^8 - 1$.
Maximum event counting rate is 150 MHz.

TIME-DELAYED MODE: the trigger can be armed by an edge on any source, trigger by the first edge on any other source after a specified time has elapsed. The delay time can be set from 20 ns to 5 seconds.

DISPLAY

Data Display Resolution: 501 points horizontally (full-scale) by 256 points vertically.

Data Display Formats

SPLIT SCREEN: each channel display is four divisions high.

FULL SCREEN: the two channels are overlaid. Each channel display is eight divisions high.

Display Modes

VARIABLE PERSISTENCE: the time that each data point is retained on the display can be varied from 200 ms to 10 seconds, or it can be displayed indefinitely.

Table 1-2. Supplemental Characteristics (Continued)

Display Modes (Continued)

AVERAGING: the number of averages can be varied from 1 to 2048 in powers of 2. On each acquisition, $1/n$ times the new data is added to $(n-1)/n$ of the previous value at each time coordinate. Averaging operates continuously; the average does not converge to a final value after n acquisitions.

GRATICULES: Full grid, axes with tic marks, or frame with tic marks.

DISPLAY COLORS: a default color selection is setup in the instrument. Different colors are used for Display background, Channel 1/Function 1, Channel 2/Function 2, background text, highlighted text, Advisories, Markers, overlapping waveforms and Memories. If desired, the colors used may be changed from the front panel or from HP-IB.

MEASUREMENT AIDS

Markers: dual voltage markers and dual time markers are available. Voltage markers can be assigned to either channel or to both channels, memories and functions.

Automatic Edge Finders: the time markers can be assigned automatically to any displayed edge of either polarity on either channel or both channels, memories and functions. The voltage markers establish the threshold reference for the time markers in this mode.

Automatic Pulse Parameter Measurements: the following pulse parameter measurements can be performed automatically (as defined by IEEE standard 194-1977, "IEEE Standard Pulse Terms and Definitions").

Frequency	Top magnitude
Period	Base magnitude
Pulse duration	Preshoot
Rise time	Overshoot
Fall time	RMS volts
Pulse amplitude	Duty cycle

Waveform Math: two independent functions are provided for waveform math. The operators are +, -, invert, versus and only. Either of the two vertical channels or any of the four waveform memories can be used as operands for the waveform math. If turned on, Function 1 is displayed in lieu of Channel 1 and Function 2 is displayed in lieu of Channel 2.

Table 1-2. Supplemental Characteristics (Continued)

SETUP AIDS

Presets: vertical deflection factor, offset, and trigger level can be preset independently on each channel for ECL or TTL levels.

Auto-Scale: pressing Auto-Scale causes vertical and horizontal deflection factors and the trigger source to be set for a display appropriate to the signals applied to the inputs. Requires a duty cycle $>0.1\%$, frequency $>50\text{Hz}$, and amplitude $>20\text{ mV}$ peak. Operative only for relatively stable input signals.

Save-Recall: ten front panel setups may be saved in non-volatile memory. If Auto-Scale is inadvertently pressed, pressing Recall followed by Auto-Scale, restores the instrument to the state prior to the last Auto-Scale executed.

Waveform Memories: four memories are provided for storage of waveforms. Only one waveform may be stored in each of these memories. These memories can be used as sources for either measurements or functions. Two additional memories are provided to store pictures. Each of these two waveform picture memories is a pixel map of the display. Any number of waveform pictures may be written into to each picture memory. Once stored, individual waveforms cannot be accessed from the picture memories. The display of any of the six memories can be turned on or off without affecting their contents. Waveforms in memory are displayed in a different color from live waveforms.

POWER REQUIREMENTS

Voltage: 115/230 V ac, -25% to $+15\%$, 48-66 Hz.

Power: 350 watts maximum, 650 VA maximum.

DIMENSIONS

Refer to outline drawing.

WEIGHT

Net: approximately 25.5 kg (56 lb).

Shipping: approximately 30.5 kg (67 lb).

Table 1-2. Supplemental Characteristics (Continued)

ENVIRONMENTAL CONDITIONS

Temperature

OPERATING: 0°C to +55°C (+32°F to +131°F).

Note: see Specification Note 1.

NON-OPERATING: -20°C to +75°C (-4°F to +167°F).

Humidity

OPERATING: up to 90% relative humidity at +40°C (+104°F).

NON-OPERATING: up to 95% relative humidity at +65°C (+149°F).

Altitude

OPERATING: up to 4600 metres (15,000 ft).

NON-OPERATING: up to 15,300 metres (50,000 ft).

Vibration: vibrated in three orthogonal axes for 15 minutes each axes; 0.38 mm (0.015 in.) peak-to-peak excursion; 5 to 55 Hz; 1 minute/octave sweep.

NOTES:

1. DIMENSIONS ARE FOR GENERAL INFORMATION ONLY. IF DIMENSIONS ARE REQUIRED FOR BUILDING SPECIAL ENCLOSURES, CONTACT YOUR HP FIELD ENGINEER.
2. DIMENSIONS ARE IN MILLIMETRES AND (INCHES).

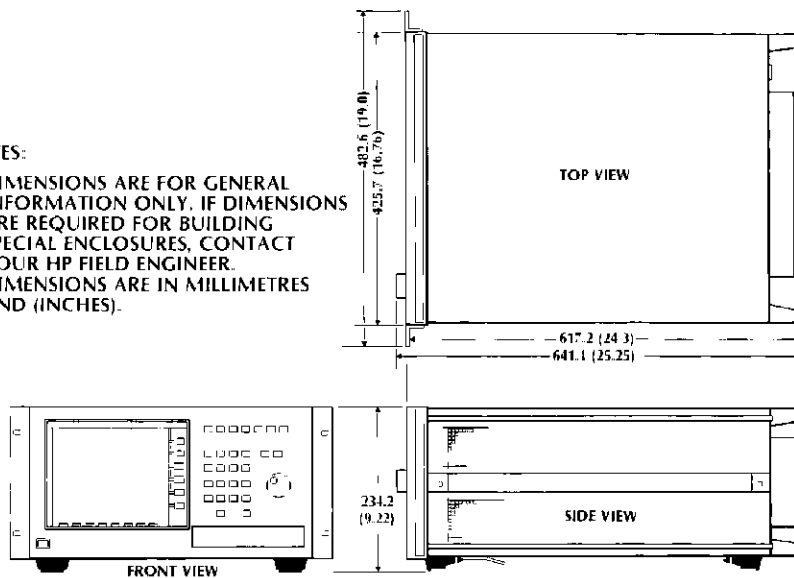

1-4. INSTRUMENTS COVERED BY MANUAL

The oscilloscope serial number is located on the rear panel. Hewlett-Packard uses a two-part serial number consisting of a four-digit prefix and a five-digit suffix separated by a letter (0000A00000). The prefix is the same for all identical oscilloscopes and changes only when a modification is made that affects parts compatibility. The suffix is assigned and is different for each oscilloscope. This manual applies directly to oscilloscopes with the serial prefix shown on the title page.

An oscilloscope manufactured after the printing of this manual may have a serial number prefix that is not listed on the title page. This unlisted serial prefix indicates the oscilloscope is different from those described in this manual. The manual for this newer oscilloscope is accompanied by a Manual Changes supplement. This supplement contains "change information" that explains how to adapt the manual to the newer oscilloscope.

In addition to change information, the supplement may contain information for correcting errors in the manual. To keep this manual as current and accurate as possible, Hewlett-Packard recommends that you periodically request the latest Manual Changes supplement. The supplement for this manual is identified with the manual print date and part number, both of which appear on the manual title page. Complimentary copies of the supplement are available from Hewlett-Packard.

1-5. DESCRIPTION

The HP Model 54110D is a fully-programmable 1 GHz digitizing oscilloscope with a 9 inch color display. The 54110D is capable of automated measurements, digital storage, pre-trigger display, configurable inputs and triggering on complex digital waveforms.

The color display of the 54110D provides 16 colors which are mapped to provide specific colors for specific display functions. For example, channel 1 is displayed in yellow, channel 2 is displayed in green and error messages are displayed in red.

To insure proper functioning of the 54110D, extensive self-tests have been designed in. These self-tests are in addition to internal diagnostics which aid in efficient fault locating and repair if a failure does occur.

1-6. LINE VOLTAGE SELECTION

CAUTION

To prevent damage to the oscilloscope, make sure the line voltage selector switch is in the correct setting for your AC voltage source.

The 54110D requires a power source of 115 or 230 Vac +15/-25 percent; 48-66 Hertz single phase. Power consumption is 350 watts or 650 VA maximum.

A blade-type screwdriver may be used to change the position of the line select switch. Figure 1-1 shows the line select switch in the 115 V position.

Once the correct setting of the line select has been made, the correct circuit breaker trip current is selected. When 115 Vac is selected the trip current is 5 amps. When 230 Vac is selected the trip current is 3 amps.

1-7. GROUNDING REQUIREMENTS

WARNING

To protect operating personnel from possible injury or death, the chassis must be properly grounded. To avoid this hazard, the proper power cord must be used and the power cord ground must NOT be defeated. Refer to table 1-3 for power cable description and application.

The 54110D is supplied with a 3-wire power cable which, when connected to an appropriate power outlet, grounds the chassis of the oscilloscope. To preserve this protection feature, do not operate the oscilloscope from a power outlet which has no grounded connection.

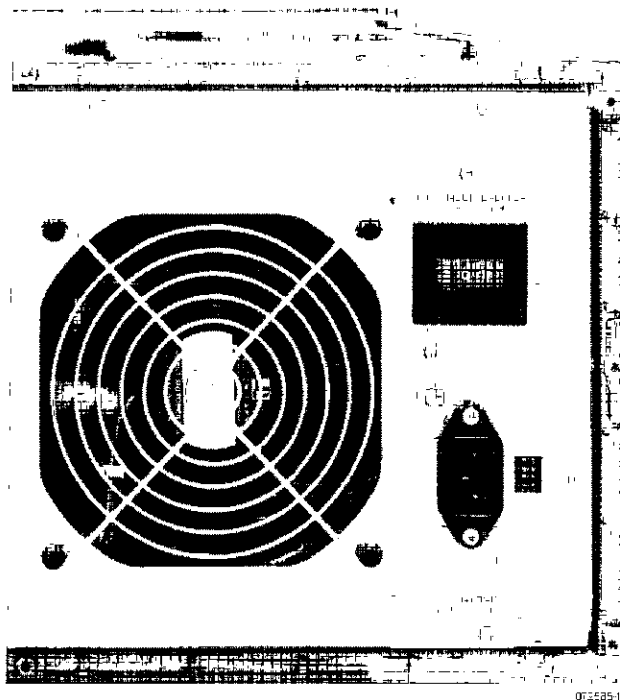





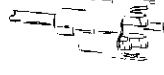



Figure 1-1. Power Module.

Table 1-1. AC Power Cables

PLUG TYPE	CABLE PART NO.	PLUG DESCRIPTION	LENGTH IN *CM	COLOR	COUNTRY
OPT 900 250V 	8120-1351 8120-1703	Straight *BS1363A 90°	90 228 90 228	Gray Mint Gray	United Kingdom, Cyprus, Nigeria, Zimbabwe Singapore
OPT 901 250V 	8120-1369 8120-0696	Straight *NZSS198 ASC 90°	79 200 87 221	Gray Mint Gray	Australia, New Zealand
OPT 902 250V 	8120-1689 8120-1692 8120-2857	Straight *CEE7-Y11 90° Straight (Shielded)	79 200 79 200 79 200	Mint Gray Mint Gray Coco Brown	East and West Europe, Saudi Arabia, So Africa, India (Unpolarized in many nations)
OPT 903 125V 	8120-1378 8120-1521 8120-1992	Straight *NEMA5-15P 90° Straight (Medical UL544)	90 228 90 228 96 244	Jade Gray Jade Gray Black	United States Canada, Japan (100V or 200V), Mexico, Philippines, Taiwan
OPT 904 250V 	8120-0698	Straight *NEMA6-15P	90 229	Black	United States Canada
OPT 905 250V 	8120-1396 8120-1625	CEE22-V1 (Systems Cabinet use) 250V	30 76 96 244	Black Black	
OPT 906 250V 	8120-2104 8120-2296	Straight *SEV1011 1959-24507 Type 12 90°	79 200 79 200	Mint Gray Mint Gray	Switzerland
OPT 912 220V 	8120-2956 8120-2957	Straight *DHCK107 90°	79 200 79 200	Mint Gray Mint Gray	Denmark

*Part number shown for plug is industry identifier for plug only. Number shown for cable is HPPart Number for complete cable including plug

E = Earth Ground
L = Line
N = Neutral

1-8. OPTIONS

The following options are available for the HP 54110D:

- Option 908 - Rack mount kit
- Option 910 - One additional Operating and Programming manual
- Option 900-902, 904, 906 and 912 - Power cord options (see table 1-3)

1-9. ACCESSORIES SUPPLIED

The following accessories are supplied with the HP 54110D:

- HP 54002A 50 Ω input pod (quantity 4)
- Operating and Programming manual (quantity 1)
- Service manual (quantity 1)
- USA power cord (quantity 1)

1-10. RECOMMENDED TEST EQUIPMENT

Equipment required to maintain the 54110D is listed at the beginning of each of the manual sections where the equipment is needed. The three sections requiring test equipment are Performance tests (Section II), Adjustments (Section III), and Service (Section VI).

1-11. PACKAGING FOR SHIPMENT

If it becomes necessary to ship the oscilloscope, original packaging i.e., the containers and material identical to those used in factory packaging are available from Hewlett-Packard. If the oscilloscope is being returned to Hewlett-Packard for servicing, attach a tag indicating the type of servicing required, return address, model number, and full serial number. Mark the container FRAGILE. In any correspondence refer to the oscilloscope by model number and full serial number.

If other packaging is to be used the following general instructions for repackaging with commercially available materials should be followed:

- a. Wrap the oscilloscope in heavy paper or plastic. If you are shipping the unit to a Hewlett-Packard office or service center be sure to attach a tag to the oscilloscope indicating the type of service required, return address, model number and full serial number.
- b. Use a strong shipping container. A double wall carton made of 2.4 MPa (350 psi) test material is adequate.
- c. Use a layer of shock absorbing material 75 to 100 mm (3 to 4 inches) thick around all sides of the instrument to provide firm cushioning and prevent movement inside the container. Protect the control panel with cardboard.
- d. Seal the shipping container securely.
- e. Mark the shipping container FRAGILE to insure careful handling.
- f. In any correspondence, refer to oscilloscope by model number and full serial number.

Performance Tests



SECTION II

PERFORMANCE TESTS

2-1. INTRODUCTION

The procedures in this section test the instrument's electrical performance using specifications in Section I as performance standards. All tests can be performed without access to the interior of the instrument

2-2. PERFORMANCE TEST EQUIPMENT REQUIRED

Equipment required for performance tests is listed in table 2-1. Any equipment that satisfies critical specifications given in the table may be substituted.

Table 2-1. Recommended Performance Test Equipment.

INSTRUMENT	CRITICAL SPECIFICATIONS	RECOMMENDED MODEL
Function Generator	50 MHz Sinewave and squarewave	HP Model 8116A
Sweep Oscillator	1.3 GHz Leveled output	HP Model 8620C/86220A
Signal Generator	Stable 500 MHz output with attenuator	HP Model 8656B/001
Pulse Generator	Risetime <100 ps	Tektronix TYPE 284
Digital Voltmeter	>0.3% accuracy at 1 Vdc	HP Model 3478A
Power Divider	3dB 50 Ohm Splitter	HP Model 11667A

2-3. TEST RECORD

Results of performance tests may be tabulated on the Performance Test Record (table 2-2) at the end of the procedures. The Test Record lists all of the tested specifications and their acceptable limits. The results recorded at incoming inspection can be used for comparison in periodic maintenance and troubleshooting and after repairs or adjustments.

2-4. CALIBRATION CYCLE

This instrument requires periodic verification of performance. The instrument should be checked using the following performance tests at least every six months. If the instrument is in use more than one shift per day or in an extremely dirty environment the performance verification should be performed at closer intervals.

2-5. PERFORMANCE TEST PROCEDURES

NOTE

Allow instrument to warm up for at least 30 minutes prior to beginning performance tests.

NOTE

HP Model 54002A 50 Ω 1:1 pod must be used for performance tests.

Performance Tests

2-6. VERTICAL ACCURACY TEST

Description:

Vertical accuracy of both channels is checked by applying several known voltage levels and making DELTA V measurements on each. Each DELTA V reading must be within specified limits.

Equipment Required:

Function Generator HP Model 8116A
 Digital Voltmeter HP Model 3478A

Instrument Setup:

54110D:

Channel 1 - VOLTS/DIV - 1 V
 - OFFSET - 0 V

 Timebase - SEC/DIV - 1 us
 - Auto

 Display - Graticule - Frame
 - Split Screen - Off
 - AVERAGES - 256

 Channel 2 - DISPLAY - OFF

Function Generator:

Offset - ON
 - AMP 5.00 V

 Waveform - ALL OFF

Digital Voltmeter:

DC Volts

Procedure:

1. Connect function generator output to channel 1 and digital voltmeter.

NOTE

While observing the DVM, set the function generator output level to the voltage required for each of the following steps.

2. Adjust function generator offset for +5.00 V and set the 54110D OFFSET to +5 V.
3. Make a DELTA V measurement by pressing AUTO TOP-BASE and 50-50%.
4. The V(1) voltage should be within 4.77 V and 5.23 V.

Performance Tests

2-6. VERTICAL ACCURACY TEST (Continued)

5. Change function generator offset to -5.00V and set the 54110D OFFSET for -5.00 V
 6. Make a DELTA V measurement by pressing AUTO TOP-BASE and 50-50%.
 7. The V(1) voltage should be within -4.77 V and -5.23 V.
 8. Adjust function generator offset for -120 mV and set the 54110D OFFSET to -120 mV.
 9. Change the 54110D vertical sensitivity to 10 mV/division.
 10. Make a DELTA V measurement by pressing AUTO TOP-BASE and 50-50%.
 11. The V(1) voltage should be within -116 mV and -124 mV.
 12. Change function generator offset to +120 mV and set the 54110D OFFSET to +120 mV
 13. Make a DELTA V measurement by pressing AUTO TOP-BASE and 50-50%.
 14. The V(1) voltage should be within 116 mV and 124 mV.
 15. Repeat steps 2 through 14 for channel 2.
-

2-7. BANDWIDTH TEST

Description:

Bandwidth is checked by insuring displayed signal is less than 3dB down from DC to 1 GHz.

Equipment Required:

Sweep Oscillator HP Model 8620C/86220A

Performance Tests

2-7. BANDWIDTH TEST (Continued)

Instrument Setup:

54110D Setup:

Channel 1 - Mode - Normal
 & - VOLTS/DIV - 200 mV/div
 Channel 2 - OFFSET - 0V

 Timebase - SEC/DIV - 2 ms
 - Delay ref at - left
 - sweep - trg'd

 Trigger - Mode - Edge
 - Source - Chan 1
 - LEVEL - +700 mV
 - Slope - pos
 - HOLDOFF Time - 21 ms

 Display - Mode - Normal
 - DISPLAY TIME - 200 ms
 - Split Screen - Off

 Delta V - Marker 1 at +564 mV
 - Marker 2 at -564 mV

Sweep Oscillator:

Start marker - .01 GHz
 Stop marker - 1.2 GHz
 CW marker - 1.0 GHz
 Level - +9 dBm
 Trigger - internal
 Time - 0.01
 Markers - AMPL
 Marker sweep - ON

Procedure:

1. Connect sweep oscillator output to channel 1, turn channel 1 on and channel 2 off.
 2. Adjust sweep oscillator output level until displayed signal just fills 8 divisions vertically.
 3. Adjust sweep oscillator time vernier until displayed waveform is 10 divisions in length.
 4. Change the 54110D DISPLAY time to Infinite
 5. The DELTA V markers show the 3 dB points and each horizontal division represents approximately 120 MHz. The sweep oscillator CW MARKER (1 GHz) should be greater in amplitude than the DELTA V markers. Clearing the display will make the DELTA V markers easier to see.
 6. Connect sweep oscillator output to channel 2. Set channel 1 to off, channel 2 to on, change Trigger Source to channel 2 and Trigger Level to 500 mV.
 7. Repeat steps 2 through 5 for channel 2.
-

Performance Tests

2-8. STEP RESPONSE (RISETIME) TEST

Description:

Tests Step Response (Risetime) by applying a fast risetime pulse to the 54110D and making an automatic risetime measurement.

Equipment Required:

Pulse Generator Tektronix TYPE 284

Instrument Setup:

54110D:

Channel 1	- Mode	- Normal
&	- VOLTS/DIV	- 50 mV/div
Channel 2	- OFFSET	- Center waveform at \approx 120 mV
Timebase	- SEC/DIV	- 500 ps/div
	- DELAY	- 0 ns
	- Delay ref at	- center
Trigger	- Mode	- Edge
	- Source	- channel 1
	- LEVEL	- +120 mV
	- Slope	- Pos
	- HOLDOFF TIME	- 70 ns
Display	- Mode	- Averaged
	- AVERAGES	- 8
	- Split Screen	- OFF

Pulse Generator:

Mode - Pulse

Procedure:

1. Connect pulse output of the pulse generator to channel 1, turn channel 1 on and channel 2 off.
 2. Select MEASURE menu and make an automatic RISEtime measurement.
 3. Risetime should be \leq 350 ps.
 4. Connect pulse output of the pulse generator to channel 2
 5. Set channel 1 to OFF, channel 2 to ON, Trigger Source to channel 2, and Trigger Level to 120 mV.
 6. Select MEASURE menu and make an automatic RISEtime measurement.
 7. Risetime should be \leq 350 ps.
-

Performance Tests

2-9. TIME INTERVAL ACCURACY TEST

Description:

The horizontal crossing of an input signal (at a minimum delay value) is set to center screen. The delay values are then increased and the crossing is observed to verify that it remains at center screen.

NOTE

Perform software calibration as directed by the CAL menu. DELAY and CHANNEL TO CHANNEL skew must be properly set. Refer to section 6 of the Operating and Programming Manual for the CAL operation.

Equipment Required:

Signal Generator HP Model 8656B/001

Instrument Setup:

Signal Generator:

Frequency - 500 MHz
 Amplitude - 200 mV

Procedure:

CHANNEL 1 ACCURACY

1. Connect signal generator to both channel 1 and 2 then press AUTO-SCALE.
2. Set the 54110D as follows:

Channel 2 to Off	Channel 1 & 2 VOLTS/DIV to 40 mV
Trigger Slope to Positive	Channel 1 & 2 OFFSET to 0 V
Trigger Source 1	Trigger LEVEL 1,2,3 to 0 V
TIMEBASE to 100 ps/div	Split Screen to Off
AVERAGES to 64	
3. Adjust Trigger LEVEL so the positive edge crosses exactly at center screen.
4. Change DELAY to 2 ns and verify positive horizontal crossing occurs within 1 division of center screen.
5. Change DELAY to 10 ns and verify positive horizontal crossing occurs within 1 division of center screen.

Performance Tests

2-9. TIME INTERVAL ACCURACY TEST (Continued)

6. Change DELAY to 18 ns and verify positive horizontal crossing occurs within 1 division of center screen.
7. Change DELAY to 26 ns and verify positive horizontal crossing occurs within 1 division of center screen.
8. Change DELAY to 5 us and verify positive slope crossing occurs within 1 division of center screen.

CHANNEL TO CHANNEL ACCURACY

9. Set channel 1 to OFF and channel 2 to ON. TRIG SOURCE remains 1. Set DELAY to 0 ns.
10. Adjust Trigger LEVEL so the positive edge exactly crosses at center screen.
11. Change DELAY to 2 ns and verify positive horizontal crossing occurs within 2 divisions of center screen.
12. Change DELAY to 10 ns and verify positive horizontal crossing occurs within 2 divisions of center screen.
13. Change DELAY to 18 ns and verify positive horizontal crossing occurs within 2 divisions of center screen.
14. Change DELAY to 26 ns and verify positive horizontal crossing occurs within 2 divisions of center screen.
15. Change DELAY to 5 us and verify positive slope crossing occurs within 1 division of center screen.

CHANNEL 2 ACCURACY

16. Set channel 2 to ON, set channel 1 to OFF, and select TRIG SOURCE 2. Set DELAY to 0 ns.
17. Adjust Trigger LEVEL so the positive edge exactly crosses at center screen.
18. Change DELAY to 2 ns and verify positive horizontal crossing occurs within 1 division of center screen.
19. Change DELAY to 10 ns and verify positive horizontal crossing occurs within 1 division of center screen.

Performance Tests

2-9. TIME INTERVAL ACCURACY TEST (Continued)

- 20. Change DELAY to 18 ns and verify positive horizontal crossing occurs within 1 division of center screen.
 - 21. Change DELAY to 26 ns and verify positive horizontal crossing occurs within 1 division of center screen.
 - 22. Change DELAY to 5 us and verify positive slope crossing occurs within 1 division of center screen.
-

2-10. TRIGGER SENSITIVITY TEST

Description:

When a 100 MHz signal is applied to either channel, the oscilloscope must trigger. The signal must remain coherent (triggered) as the input amplitude is decreased and the frequency is increased.

Equipment Required:

Signal Generator HP Model 8656B/001
 Power Divider HP Model 11667A

Instrument Setup:

54110D Setup:

Channel 1 - Mode - Normal
 & - VOLTS/DIV - 10 Mv
 Channel 2 - OFFSET - 0 V

Timebase - SEC/DIV - 2 ns
 - Delay - 0 ns

Trigger - Mode - Edge
 - Source - channel 1
 - LEVEL - 0 V

Display - Mode - Averaged
 - AVERAGES - 8
 - Split Screen - Off

Signal Generator:

Frequency - 100 MHz
 Amplitude - 9 mV
 Amp Increment - 0.1 mV

Performance Tests

2-10. TRIGGER SENSITIVITY TEST (Continued)

Procedure:

1. Set channel 1 and channel 2 to ON.
 2. Connect signal generator to channel 1.
 3. Decrease signal generator output amplitude until a 10 mV peak-to-peak waveform is displayed
Waveform must be coherent (triggered)
 4. Connect signal generator to channel 2 and set Trigger Source to channel 2 and Trigger Level to 0 V.
 5. A 10 mV peak-to-peak waveform should be displayed and must be coherent (triggered).
 6. Change the 54110D SEC/Div to 500 ps.
 7. Change signal generator frequency to 500 MHz and adjust amplitude to 20 mV peak-to-peak.
Waveform should be coherent (triggered).
 8. Connect signal generator output to channel 1.
 9. Change trigger source to channel 1.
 10. Waveform should be coherent (triggered).
 11. Split the signal with a power divider and apply to channel 3.
 12. Adjust signal generator amplitude until an 80 mV peak-to-peak waveform is displayed
 13. Select TRIG SOURCE 3 and set Trigger Level to 0 V. Waveform must be coherent.
 14. Change signal generator frequency to 100 MHz and adjust amplitude to 40 mV peak-to-peak
 15. Change the 54110D SEC/Div to 2 ns.
 16. Waveform should be coherent.
 17. Split the signal with a power divider and apply to channel 4.
 18. Select TRIG SOURCE 4 and set Trigger Level to 0 V. Waveform must be coherent.
 19. Change signal generator frequency to 500 MHz and adjust amplitude to 80 mV peak-to-peak.
 20. Change the 54110D SEC/Div to 500 ps
 21. Waveform should be coherent.
-

Performance Tests

2-11. APERTURE JITTER TEST

Description:

Aperture jitter is tested by measuring the width of the displayed waveform after it is allowed to build for 3 minutes in infinite persistence.

Equipment Required:

Pulse Generator Tektronix TYPE 284

Instrument Setup:

54110D Setup:

Channel 1 - Mode - Normal
 & - VOLTS/DIV - 50 mV
 Channel 2 - OFFSET - +120 mV

Timebase - SEC/DIV - 100 ps
 - sweep - trg'd

Trigger - Source - 1
 - LEVEL - +120 mV

Display - Mode - Normal
 - Display Time - Infinite Persistence
 - Split Screen - Off

Pulse Generator:

Mode - Pulse

Procedure:

1. Connect pulse generator output to channel 1 and allow display to build for a minimum of 3 minutes. Use delay to center the leading edge of waveform.
2. Using DELTA T markers, measure the width of the display at the center crossing (X axis width). Width shall be ≤ 300 ps peak-to-peak.
3. Set channel 1 to OFF and channel 2 to ON
4. Change TRIG SOURCE to 2, set Trigger Level to 120 mV, and connect pulse generator output to channel 2
5. Press CLEAR DISPLAY
6. Allow display to build for a minimum of 3 minutes.
7. Using DELTA T markers, measure the width of the display at the center crossing (X axis width). Width shall be ≤ 300 ps peak-to-peak.

Performance Tests

Notes



Table 2-2. Performance Test Record

HEWLETT-PACKARD MODEL 54110D DIGITAL OSCILLOSCOPE		Tested by _____ Work Order No. _____ Date _____																																																		
SERIAL NO. _____																																																				
Recommended Calibration Interval _____ Months																																																				
Paragraph Number	Test	Results																																																		
2-6	Vertical Accuracy Test	<table style="width: 100%; border-collapse: collapse;"> <tr> <td style="padding: 2px 5px;">channel 1</td> <td style="padding: 2px 5px;">Minimum -- 4.77 V</td> </tr> <tr> <td style="padding: 2px 5px;">step 4</td> <td style="padding: 2px 5px;">Actual _____ V</td> </tr> <tr> <td></td> <td style="padding: 2px 5px;">Maximum -- 5.23 V</td> </tr> <tr> <td style="padding: 2px 5px;">step 7</td> <td style="padding: 2px 5px;">Minimum -- -4.77 V</td> </tr> <tr> <td></td> <td style="padding: 2px 5px;">Actual _____ V</td> </tr> <tr> <td></td> <td style="padding: 2px 5px;">Maximum -- -5.23 V</td> </tr> <tr> <td style="padding: 2px 5px;">step 11</td> <td style="padding: 2px 5px;">Minimum -- -116 mV</td> </tr> <tr> <td></td> <td style="padding: 2px 5px;">Actual _____ mV</td> </tr> <tr> <td></td> <td style="padding: 2px 5px;">Maximum -- -124 mV</td> </tr> <tr> <td style="padding: 2px 5px;">step 14</td> <td style="padding: 2px 5px;">Minimum -- 116 mV</td> </tr> <tr> <td></td> <td style="padding: 2px 5px;">Actual _____ mV</td> </tr> <tr> <td></td> <td style="padding: 2px 5px;">Maximum -- 124 mV</td> </tr> <tr> <td style="padding: 2px 5px;">channel 2</td> <td></td> </tr> <tr> <td style="padding: 2px 5px;">step 4</td> <td style="padding: 2px 5px;">Minimum -- 4.77 V</td> </tr> <tr> <td></td> <td style="padding: 2px 5px;">Actual _____ V</td> </tr> <tr> <td></td> <td style="padding: 2px 5px;">Maximum -- 5.23 V</td> </tr> <tr> <td style="padding: 2px 5px;">step 7</td> <td style="padding: 2px 5px;">Minimum -- -4.77 V</td> </tr> <tr> <td></td> <td style="padding: 2px 5px;">Actual _____ V</td> </tr> <tr> <td></td> <td style="padding: 2px 5px;">Maximum -- -5.23 V</td> </tr> <tr> <td style="padding: 2px 5px;">step 11</td> <td style="padding: 2px 5px;">Minimum -- -116 mV</td> </tr> <tr> <td></td> <td style="padding: 2px 5px;">Actual _____ mV</td> </tr> <tr> <td></td> <td style="padding: 2px 5px;">Maximum -- -124 mV</td> </tr> <tr> <td style="padding: 2px 5px;">step 14</td> <td style="padding: 2px 5px;">Minimum -- 116 mV</td> </tr> <tr> <td></td> <td style="padding: 2px 5px;">Actual _____ mV</td> </tr> <tr> <td></td> <td style="padding: 2px 5px;">Maximum -- 124 mV</td> </tr> </table>	channel 1	Minimum -- 4.77 V	step 4	Actual _____ V		Maximum -- 5.23 V	step 7	Minimum -- -4.77 V		Actual _____ V		Maximum -- -5.23 V	step 11	Minimum -- -116 mV		Actual _____ mV		Maximum -- -124 mV	step 14	Minimum -- 116 mV		Actual _____ mV		Maximum -- 124 mV	channel 2		step 4	Minimum -- 4.77 V		Actual _____ V		Maximum -- 5.23 V	step 7	Minimum -- -4.77 V		Actual _____ V		Maximum -- -5.23 V	step 11	Minimum -- -116 mV		Actual _____ mV		Maximum -- -124 mV	step 14	Minimum -- 116 mV		Actual _____ mV		Maximum -- 124 mV
channel 1	Minimum -- 4.77 V																																																			
step 4	Actual _____ V																																																			
	Maximum -- 5.23 V																																																			
step 7	Minimum -- -4.77 V																																																			
	Actual _____ V																																																			
	Maximum -- -5.23 V																																																			
step 11	Minimum -- -116 mV																																																			
	Actual _____ mV																																																			
	Maximum -- -124 mV																																																			
step 14	Minimum -- 116 mV																																																			
	Actual _____ mV																																																			
	Maximum -- 124 mV																																																			
channel 2																																																				
step 4	Minimum -- 4.77 V																																																			
	Actual _____ V																																																			
	Maximum -- 5.23 V																																																			
step 7	Minimum -- -4.77 V																																																			
	Actual _____ V																																																			
	Maximum -- -5.23 V																																																			
step 11	Minimum -- -116 mV																																																			
	Actual _____ mV																																																			
	Maximum -- -124 mV																																																			
step 14	Minimum -- 116 mV																																																			
	Actual _____ mV																																																			
	Maximum -- 124 mV																																																			

HP 54110D - Performance Tests

Paragraph Number	Test	Results
2-7	Bandwidth Test channel 1 step 5 channel 2 step 5	CW Marker greater than DELTA V markers yes ____ no ____ CW Marker greater than DELTA V markers yes ____ no ____
2-8	Step Response (Risetime) Test channel 1 step 3 channel 2 step 3	Risetime is ≤ 350 ps yes ____ no ____ Risetime is ≤ 350 ps yes ____ no ____
2-9	Time Interval Accuracy Test channel 1 step 4 step 5	Minimum-1 division left of center screen Actual - _____ Maximum-1 division right of center screen Minimum-1 division left of center screen Actual - _____ Maximum-1 division right of center screen

Paragraph Number	Test	Results
2-9	Time Interval Accuracy Test (cont)	
	step 6	Minimum-1 division left of center screen Actual - _____ Maximum-1 division right of center screen
	step 7	Minimum-1 division left of center screen Actual - _____ Maximum-1 division right of center screen
	step 8	Minimum-1 division left of center screen Actual - _____ Maximum-1 division right of center screen
	channel to channel step 11	Minimum-2 division left of center screen Actual - _____ Maximum-2 division right of center screen

Paragraph Number	Test	Results
2-9	Time Interval Accuracy	
	Test (cont)	
	step 12	Minimum-2 division left of center screen Actual - _____ Maximum-2 division right of center screen
	step 13	Minimum-2 division left of center screen Actual - _____ Maximum-2 division right of center screen
	step 14	Minimum-2 division left of center screen Actual - _____ Maximum-2 division right of center screen
step 15	Minimum-1 division left of center screen Actual - _____ Maximum-1 division right of center screen	

Paragraph Number	Test	Results
2-9	Time Interval Accuracy channel 2 Test (cont) step 18	Minimum-1 division left of center screen
		Actual - _____
		Maximum-1 division right of center screen
	step 19	Minimum-1 division left of center screen
		Actual - _____
		Maximum-1 division right of center screen
	step 20	Minimum-1 division left of center screen
		Actual - _____
		Maximum-1 division right of center screen
	step 21	Minimum-1 division left of center screen
		Actual - _____
		Maximum-1 division right of center screen

Paragraph Number	Test	Results
2-9	Time Interval Accuracy Test (cont) step 22	Minimum-1 division left of center screen Actual - _____ Maximum-1 division right of center screen
2-10	Trigger Sensitivity Test channel 1 step 3 channel 2 step 5 step 7 channel 1 step 10 Trigger channel 3 step 13 step 16	Waveform remains Coherent Yes _____ No _____ Waveform remains Coherent Yes _____ No _____ Waveform remains Coherent Yes _____ No _____ Waveform remains Coherent Yes _____ No _____ Waveform remains Coherent Yes _____ No _____

Paragraph Number	Test	Results
2-10	Trigger Sensitivity Test (cont) Trigger channel 4 step 13 step 16	Waveform remains Coherent Yes ___ No ___ Waveform remains Coherent Yes ___ No ___
2-11	Aperture Jitter Test channel 1 step 2 channel 2 step 7	Width \leq 300 ps peak-to-peak Yes ___ No ___ Width \leq 300 ps peak-to-peak Yes ___ No ___

Adjustments



SECTION III

ADJUSTMENTS

3-1. INTRODUCTION

This section describes the adjustments and checks required to return the instrument to peak operating capabilities after repairs have been made. Included in this section is a table of Recommended Test Equipment (table 3-1).

3-2. CALIBRATION INTERVAL

To maintain proper calibration, these adjustments should be made at approximately one year intervals when the instrument is being used under normal operating conditions. Some or all of these adjustments may need to be made after repairs have been completed. If the instrument is used more than one shift per day or in an extremely dirty or dusty environment the adjustment interval may need to be shorter.

WARNING

Read the Safety Summary at the front of this manual before performing adjustment procedures. The apparatus shall be disconnected from all voltage sources before it is opened for any adjustment, replacement, maintenance, or repair.

3-3. ADJUSTMENT TEST EQUIPMENT REQUIRED

Required test equipment is listed in Table 3-1 Recommended Test Equipment.

NOTE

HP Model 54002A 50 Ω 1:1 pod must be used for adjustments.

Table 3-1. Recommended Adjustment Test Equipment.

INSTRUMENT	CRITICAL SPECIFICATIONS	RECOMMENDED MODEL
Function Generator	50 Hz to 10 MHz sine wave, square wave, triangle	HP Model 8116A
Programmable Pulse Generator	Adjustable Pulse Width Adjustable leading and trailing edge slope Adjustable Trigger Delay	HP Model 8161A/002
Digital Voltmeter	>0.3% accuracy at 1 Vdc	HP Model 3478A
Oscilloscope	Dual channel 5 ns sweep with X10 magnification	HP Model 1725A
Pulse Generator	Flat Pulse < 1% perturbations	Tektronix Model PG506
Pulse Generator	Risetime ≤ 70 ps	Tektronix Type 284
Frequency Counter	Range: 50 MHz	HP Model 5381A
Divider Probe	10:1 division ratio	HP Model 10017A
Divider Probe	50 Ω resistive divider	HP Model 10020A
Product Support Kit	No substitute	HP Part No. 54100-69002
Alignment Tool	Non-metallic < 3mm diameter	Sony* Part No. 4-367-065-01

* Sony Manufacturing Company of America
16450 West Bernardo Dr.
San Diego, CA 92127

Adjustments

3-4. POWER SUPPLY ADJUSTMENTS

NOTE

*The power supply voltages are factory set and **DO NOT** require adjustment in the field. **DO NOT** make any power supply adjustments during normal calibration.*

Description:

This procedure is provided to adjust the power supply voltages in cases where either of the power supplies has been inadvertently mis-adjusted

Equipment Required:

Digital Voltmeter HP Model 3478A

Instrument Setup:

54110D:

None

Digital Voltmeter:

DC Volts
4 and 1/2 Digits
Autozero - On

Digital Power Supply Board Adjustment Locations



Analog Power Supply Board Adjustment Locations

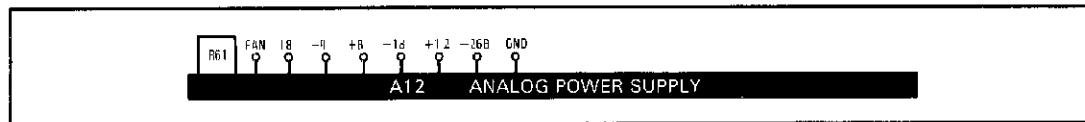

Adjustments

3-4. POWER SUPPLY ADJUSTMENTS (Continued)

Digital Power Supply Procedure:

1. Disconnect power cord and remove power supply shield

WARNING

Hazardous voltages capable of causing injury or death are present on the AC Power Supply board (A11) when power is applied and for a period of time after power is removed from the instrument. To avoid this hazard, DO NOT remove the top power supply shield until the LED on the AC Power Supply board (A11) is extinguished. This LED is visible through an inspection hole in the cover labeled "+300 V WHEN LAMP IS ON".

2. Connect positive voltmeter lead to the +5 V test point (actual voltage = +5.2 V).
3. Connect negative voltmeter lead to the -5 V test point (actual voltage = -5.2 V).
4. Apply power and allow instrument to stabilize for 1 to 2 minutes.
5. Adjust A13R56 for a voltmeter reading of $10.4 \text{ Vdc} \pm 0.01 \text{ V}$.
6. Disconnect power and wait until the LED on the AC Power Supply board (A11) is extinguished before re-installing top power supply shield

Adjustments

3-4. POWER SUPPLY ADJUSTMENTS (Continued)

Analog Power Supply Procedure:

NOTE

*The instrument **MUST** be stabilized at ambient temperature (+25°C) with power off before this adjustment is made. This voltage will rise as internal temperature increases.*

1. Connect positive voltmeter lead to the FAN test point
 2. Connect negative voltmeter lead to the -18 V test point.
 3. Adjust A12R61 for a voltmeter reading of 9.5 V.
-

Adjustments

3-5. DC OFFSET ADJUSTMENT

Description:

DC Offset is adjusted to position baseline at mid screen when no signal is applied

Equipment Required:

None

Instrument Setup:

54110D:

- | | | |
|---------------|----------------|--------------|
| Channel 1 & 2 | - Mode | - Normal |
| | - Display | - On |
| | - VOLTS/DIV | - 100 mV/div |
| | - OFFSET | - 0 V |
| then; | - Mode | - Magnify |
| | - WINDOW SIZE | - 50 mV |
| | - POSITION | - 0.0 V |
| | | |
| Timebase | - SEC/DIV | - 100 us/div |
| | - DELAY | - 0 |
| | - Delay Ref at | - Center |
| | - Auto | |
| | | |
| Display | - Mode | - Averaged |
| | - AVERAGES | - 8 |
| | - Graticule | - Axes |

Analog to Digital Board (A5/A7) Adjustment Locations



Sampling Board (A4/A6)

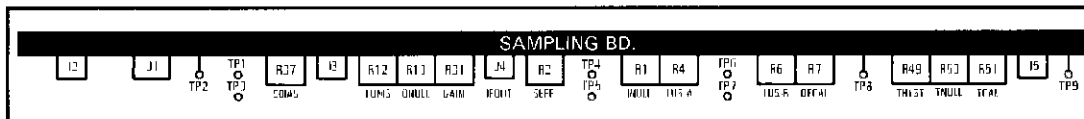

Adjustments

3-5. DC OFFSET ADJUSTMENT (Continued)

Procedure:

1. Disconnect IFOUT (J4) cable from A4 and turn channel 2 off.
 2. Adjust A5R118 (OFFSET) until baseline overlays center screen.
 3. Magnify baseline to 6.25 mV/division and fine adjust baseline to center screen
 4. Reconnect IFOUT cable to A4.
 5. Turn channel 1 off and channel 2 on.
 6. Disconnect IFOUT (J4) cable from A6
 7. Adjust A7R118 (OFFSET) until baseline overlays center screen
 8. Magnify baseline to 6.25 mV/division and fine adjust baseline to center screen.
 9. Reconnect IFOUT cable to A6.
-

Adjustments

3-6. INPUT AND OUTPUT OFFSET NULL ADJUSTMENT

Description:

While the actual voltage at the channel 1 and 2 input connectors is measured, the input null is adjusted for a minimum voltmeter reading. The output null is then adjusted until trace overlays center graticule line.

Equipment Required:

Digital Voltmeter HP Model 3478A

Instrument Setup:

54110D:

Channel 1 & 2 - Mode - Normal
 - Display - On
 - VOLTS/DIV - 10 mV/div
 - OFFSET - 0 V

Timebase - SEC/DIV - 100 us/div
 - Delay Ref at - Center
 - Auto

Display - Mode - Averaged
 - AVERAGES - 8
 - Split Screen - Off
 - Graticule - Axes

Sampling Board (A4/A6) Adjustment Locations

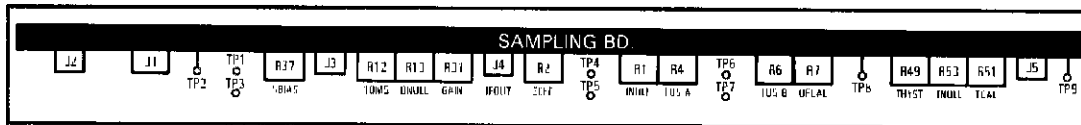

Adjustments

3-6. INPUT AND OUTPUT OFFSET NULL ADJUSTMENT (Continued)

Procedure:

NOTE

Verify the channel 1 and 2 vertical sensitivities are set to 10 mV/division.

1. Verify channel 1 offset is set to 0.00 V and turn channel 2 off.
2. Using voltmeter, monitor voltage on the channel 1 input BNC connector.
3. Adjust A4R1 (INULL) for a voltmeter reading of < 0.1 mV.
4. Change channel 1 vertical sensitivity to 100 mV/division.
5. Adjust A4R13 (ONULL) until trace overlays center graticule line.

NOTE

While making this adjustment it is helpful to press CLEAR DISPLAY key repeatedly

6. Turn channel 1 off and channel 2 on.
 7. Verify channel 2 Offset is set to 0.00 V.
 8. Using voltmeter, monitor voltage on the channel 2 input BNC connector.
 9. Adjust A6R1 (INULL) for a voltmeter reading of < 0.1 mV.
 10. Change channel 2 vertical sensitivity to 100 mV/division.
 11. Adjust A6R13 (ONULL) until trace overlays center graticule line.
-

Adjustments

3-7. SAMPLER BIAS ADJUSTMENT

Description:

Sampler bias is adjusted for an abrupt change in overshoot on the displayed waveform.

Equipment Required:

Pulse Generator Tektronix PG506

Instrument Setup:

54110D:

Will be setup during procedure

Pulse Generator:

Mode - Fast Rise
 Period - 1 ms
 Pulse Amplitude - 100 mV

Sampling Board (A4/A6) Adjustment Locations

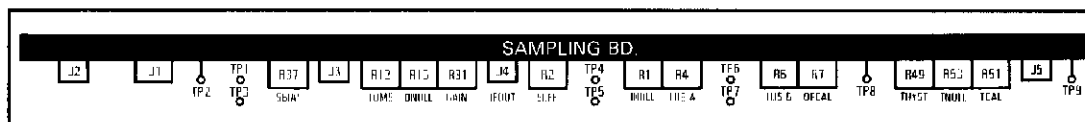

Procedure:

1. Connect positive fast rise output of the PG506 to channel 1 input using a large diameter cable (ie. RG8/U).
2. Connect trigger output of PG 506 to channel 3 input.
3. Press AUTO SCALE key.
4. Configure the 54110D as follows:

Channel 1 - Mode	- Normal	Timebase - SEC/DIV	- 20 ns/div
& - Display	- On	- DELAY	- 40 ns
Channel 2 - VOLTS/DIV	- 20 mV/div	- Delay Ref at	- Center
- OFFSET	- -50 mV		
Trigger - Mode	- Edge	Display - Mode	- Edge
- Source	- Trig 3	- AVERAGES	- 8
- LEVEL	- +0.5 V	- Split Screen	- Off
- Slope	- Positive	- Graticule	- Axes
- HOLDOFF Time	- 70 ns		

Adjustments

3-7. SAMPLER BIAS ADJUSTMENT (Continued)

5. Adjust A4R37 (SBIAS) fully clockwise (CW).
6. Short A4TP1 to ground (A4TP2).
7. Adjust A4R37 (SBIAS) counter-clockwise (CCW) until the positive portion of the pulse amplitude (>25 ns after the leading edge) abruptly increases.
8. Remove short on A4TP1. This will shift bias slightly into a stable operating point.

NOTE

The pulse response will not be completely flat but this will be corrected later.

9. Connect positive fast rise output of the PG506 to channel 2 input using a large diameter cable (ie. RG8/U).
10. Turn channel 1 off and channel 2 on.
11. Press AUTO SCALE and configure the 54110D per step 4.
12. Adjust A6R37 (SBIAS) fully clockwise (CW)
13. Short A6TP1 to ground (A6TP2).
14. Adjust A6R37 (SBIAS) counter-clockwise (CCW) until the positive portion of the pulse amplitude (>25 ns after the leading edge) abruptly increases.
15. Remove short on A6TP1. This will shift bias slightly into a stable operating point.

NOTE

The pulse response will not be completely flat but this will be corrected later.

Adjustments

3-8. FLATNESS AND SAMPLING EFFICIENCY ADJUSTMENTS

Description:

Flatness and sampling efficiency are adjusted for flattest response and minimum step on pulse 25 ms after rising edge.

Equipment Required:

Pulse Generator Tektronix PG506

Instrument Setup:

54110D:

Will be setup during procedure

Pulse Generator:

Mode - Fast Rise
 Period - 20 ms
 Pulse Amplitude - 100 mV
 Positive Output

Sampling Board (A4/A6) Adjustment Locations

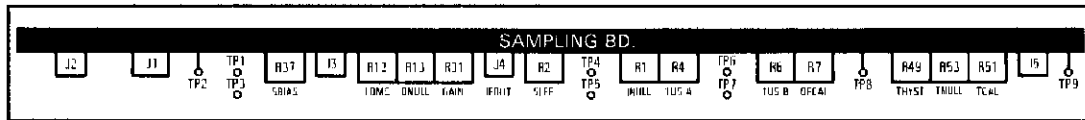

Procedure:

1. Connect positive fast rise output of the PG506 to channel 1 input using a large diameter cable (ie RG8/U).
2. Connect trigger output of PG 506 to channel 3 input.
3. Press AUTO SCALE key.
4. Configure the 54110D as follows:

Channel 1 - Mode	- Normal	Timebase - SEC/DIV	- 2 ms/div
& - Display	- On	- DELAY	- 0 s
Channel 2 - VOLTS/DIV	- 20 mV/div	- Delay Ref at	- Center
- OFFSET	- -50 mV	- Trg'd	
Trigger - Mode	- Edge	Display - Mode	- Averaged
- Source	- Channel 1	- AVERAGES	- 8
- LEVEL	- -50 mV	- Split Screen	- Off
- Slope	- Positive	- Graticule	- Axes
- HOLDOFF Time	- 70 ns		

Adjustments

3-8. FLATNESS AND SAMPLING EFFICIENCY ADJUSTMENTS (Continued)

Procedure:

5. Adjust A4R12 (10 ms) for flattest response on positive portion of pulse.
6. Change channel 1 to Magnify and set Window to 40 mV. Position to 0 V, set Magnify to On, and change Display Averages to 32
7. Readjust A4R12 (10 ms adjust) for flattest response.

NOTE

Using a DELTA V Marker for a flat reference line simplifies adjustment.

8. Change pulse generator period to 2 ms and set 54110D SEC/DIV to 1 us/div.
9. Return channel 1 mode to Normal.
10. Adjust A4R4 (1-us-A) for flattest response with no overshoot.
11. Adjust A4R6 (1-us-B) for flattest response.

NOTE

Because of interaction between adjustments, steps 10 and 11 may need to be repeated to obtain flattest response.

12. Change 54110D SEC/DIV to 20 ns/div and Delay to 40 ns.
13. Adjust A4R2 (SEFF) for the flattest pulse response possible. Periodically clearing the display while making this adjustment will make observing the new waveform easier.

NOTE

Particular care should be taken to minimize the step that occurs 25 ns after rising edge of pulse. Figure 3-1 shows the sampling efficiency when it is adjusted correctly.

Adjustments

3-8. FLATNESS AND SAMPLING EFFICIENCY ADJUSTMENTS (Continued)

14. Set the PG506 PERIOD to 20 ms, and 54110D as follows Channel 2 SEC/DIV to 2 ms, Delay to 0 s, and Average to 8.
15. Connect pulse generator output to channel 2.
16. Adjust A6R12 (10 ms) for flattest response on positive portion of the pulse.
17. Change channel 2 to Magnify and set Window to 40 mV. Position to 0 V, Magnify to On, and change Display Averages to 32.
18. Readjust A6R12 (10 ms) adjust for flattest response.
19. Change pulse generator PERIOD to 2 ms and 54110D SEC/DIV to 1 us/div.
20. Return channel 2 mode to Normal
21. Adjust A6R4 (1-us-A) for flattest response with no overshoot
22. Adjust A6R6 (1-us-B) for flattest response.

NOTE

Because of interaction between adjustments, steps 21 and 22 may need to be repeated to obtain the flattest response.

23. Change 54110D SEC/DIV to 20 ns/div and Delay to 40 ns.
24. Adjust A6R2 (SEFF) for flattest pulse response possible

Adjustments

3-8. FLATNESS AND SAMPLING EFFICIENCY ADJUSTMENTS (Continued)**NOTE**

Particular care should be taken to minimize the step that occurs 25 ns after rising edge of pulse. Figure 3-1 shows the sampling efficiency when it is adjusted correctly.

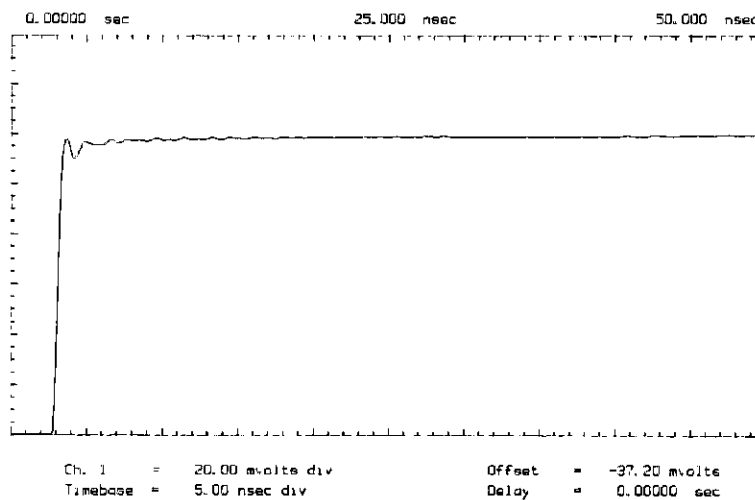

Figure 3-1. Sampling Efficiency Adjusted Correctly

Adjustments

3-9. OFFSET CALIBRATION ADJUSTMENT

Description:

With the 54110D set to the same offset value as the function generator output, the OFCAL is adjusted until the trace overlays center screen.

Equipment Required:

Function Generator HP Model 8116A
 Digital Voltmeter HP Model 3478A

Instrument Setup:

54110D:

Channel 1 - Mode - Normal
 & - Display - On
 Channel 2 - VOLTS/DIV - 100 mV/div
 - OFFSET - +1.2 V

Timebase - SEC/DIV - 20 ns/div
 - Delay Ref at - Center screen
 - Sweep - Auto

Display - Mode - Averaged
 - AVERAGES - 8
 - Split Screen - Off
 - Graticule - Axes

Function Generator:

Mode - DC
 Offset - +1.2 V
 Waveforms - All Off

Sampling Board (A4/A6) Adjustment Locations

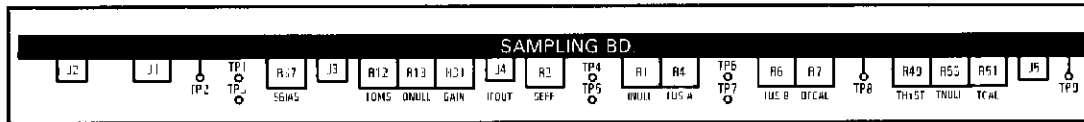

Adjustments

3-9. OFFSET CALIBRATION ADJUSTMENT (Continued)

Procedure:

1. Turn channel 2 off
 2. Connect function generator output to both the voltmeter and channel 1
 3. While monitoring voltmeter, adjust function generator output for a +1.2 V dc level
 4. Adjust A4R7 (OFCAL) until trace overlays center axis.
 5. Change 54110D channel 1 offset to -1.2 V and function generator output offset to -1.2 V.
 6. Verify trace is at center screen within ± 1 minor division.
 7. Turn channel 1 off and channel 2 on.
 8. Connect function generator output to both the voltmeter and channel 2
 9. While monitoring voltmeter, adjust function generator output for a +1.2 V dc level.
 10. Adjust A6R7 (OFCAL) until trace overlays center axis.
 11. Change 54110D channel 2 offset to -1.2 V and function generator output offset to -1.2 V.
 12. Verify trace is at center screen within ± 1 minor division.
-

Adjustments

3-10. GAIN ADJUSTMENTS

Description:

A positive dc voltage is applied to the input and the gain is adjusted until trace is in the correct position. Then a negative voltage is applied to the input and trace position is checked.

Equipment Required:

Function Generator HP Model 8116A

Instrument Setup:

54110D:

- Channel 1 & 2 - Mode - Normal
- Display - On
- VOLTS/Div - 100 mV/div
- OFFSET - 0 V

- Timebase - SEC/DIV - 50 us
- DELAY - 0
- Delay Ref at - Center screen
- Sweep - Auto

- Trigger - Mode - Edge
- Source - Chan 1

- Display - Mode - Averaged
- AVERAGES - 8
- Split Screen - Off
- Graticule - Grid

Function Generator:

- Mode - DC Offset
- Offset - +300 mV

Sampling Board (A4/A6) Adjustment Locations

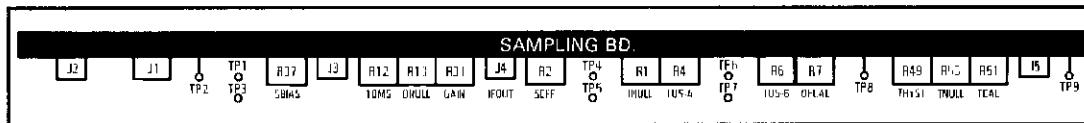

Adjustments

3-10. GAIN ADJUSTMENTS (Continued)

Procedure:

1. Connect function generator output to channel 1
2. Adjust function generator output level to +300 mV.
3. Adjust A4R31 (GAIN) until trace is 3 divisions above center screen.
4. Change the function generator output level to -300 mV.
5. Trace should now be 3 divisions below center screen

NOTE

It may be necessary to repeat steps 2 through 5 and readjust A4R31 in order to minimize the errors of these two operating points

6. Connect function generator output to channel 2
7. Adjust function generator output level to +300 mV.
8. Adjust A6R31 (GAIN) until trace is 3 divisions above center screen.
9. Change the function generator output level to -300 mV.
10. Trace should now be 3 divisions below center screen.

NOTE

It may be necessary to repeat steps 7 through 10 and readjust A6R31 in order to minimize the errors of these two operating points.

Adjustments

3-11. SAMPLING BOARD TRIGGER ADJUSTMENTS

Description:

Adjusts the Trigger Hysteresis, Trigger Offset Null, and Trigger Level.

Equipment Required:

Function Generator HP Model 8116A

Instrument Setup:

54110D:

- Channel 1 - Mode - Normal
- & - Display - On
- Channel 2 - VOLTS/DIV - 100 mV/div
- OFFSET - 0 V

- Timebase - SEC/DIV - 50 us
- DELAY - 0
- Delay Ref at - Center screen
- Auto

- Trigger - Mode - Edge
- Source - Chan 1
- LEVEL - 0 V
- Slope - Positive
- HOLDOFF Time - 70 ns

- Display - Mode - Averaged
- AVERAGES - 8
- Split Screen - Off
- Graticule - Axes

Function Generator:

- Mode - Normal
- Frequency - 1 KHZ
- Offset - 0 V
- Duty Cycle - 50%
- Waveform - Sinewave

Sampling Board (A4/A6) Adjustment Locations

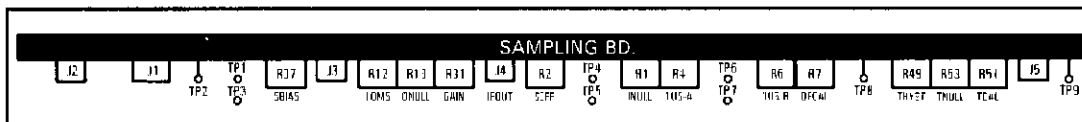

Adjustments

3-11. SAMPLING BOARD TRIGGER ADJUSTMENTS (Continued)

Procedure:

1. Trigger Hysteresis Adjustment.
 - a. Connect function generator output to channel 1
 - b. Adjust function generator output until an 8 division peak-to-peak amplitude is displayed.
 - c. In Trigger Menu, switch slope repeatedly between Pos and Neg. The difference between voltage levels at time zero between Pos and Neg is hysteresis. The actual trigger level is halfway between the two observed levels.
 - d. Adjust A4R49 (THYST) until the voltage difference (Y axis) at time zero is one minor division.
 2. Trigger Offset Null Adjustment.
 - a. Observe waveform at time zero as slope is switched.
 - b. Adjust A4R53 (TNULL) until the two voltage levels at time zero are centered above and below 0 V.
 3. Trigger Level Calibration Adjustment.
 - a. Change channel 1 Offset to 1.2 V.
 - b. Change Trigger Level to 1.2 V
 - c. Set function generator high level output (HIL) to 1.6 V and low level output (LOL) to 0.8 V.
 - d. Adjust A4R51 (TCAL) until voltage levels at time zero, as the slope is switched, are centered above and below 0 V.
 - e. Change channel 1 Offset to -1.2 V.
 - f. Change Trigger Level to -1.2 V.
 - g. Set function generator high level output (HIL) to -0.8 V, and low level output (LOL) to -1.6 V
 - h. Verify trigger level switching at center screen is within two minor divisions while switching slope.
 4. Reset trigger level to 0 V and repeat steps 1 through 3 for channel 2 and Trigger Source 2.
-

Adjustments

3-12. HF GAIN (PULSE FLATNESS) ADJUSTMENT

Description:

The pulse response of the ADC is adjusted for optimum flatness.

Equipment Required:

Calibration Generator Tektronix PG506

Instrument Setup:

54110D:

Channel 1 - Mode - Normal
& - Display - On
Channel 2 - VOLTS/DIV - 100 mV/div
- OFFSET - 0 V

Timebase - SEC/DIV - 2 ms/div
- DELAY - 0
- Delay Ref at - Center

Trigger - Mode - Edge
- Source - Trig 3
- LEVEL - +0.5 V
- Slope - positive
- HOLDOFF Time - 70 ns

Display - Mode - Averaged
- AVERAGES - 2
- Graticule - Axes

PG506:

Period - 20 ms
Pulse Amplitude - 300 mV

Analog to Digital Board (A5/A7) Adjustment Locations

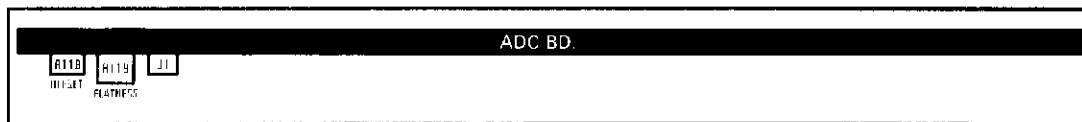

Adjustments

3-12. HF GAIN (PULSE FLATNESS) ADJUSTMENT

Procedure:

1. Connect pulse generator trigger output to channel 3
 2. Connect the positive fast rise output of calibration generator to channel 1 and set amplitude to 300 mV.
 3. Adjust A5R119 for optimum flatness
 4. Connect the positive fast rise output of calibration generator to channel 2 and set amplitude to 300 mV.
 5. Adjust A7R119 for optimum flatness.
-

Adjustments

3-13. MAIN TRIGGER BOARD CALIBRATION ADJUSTMENTS

Description:

Hysteresis, offset and trigger level are calibrated by observing the voltage level where displayed waveform crosses the zero time reference which is set to center screen.

NOTE

*The adjustment procedures in paragraphs 3-5 through 3-11 (**IN THAT ORDER**) must be performed before the trigger circuits are calibrated.*

Equipment Required:

Function Generator HP Model 8116A

Instrument Setup:

54110D:

- Channel 1 - Mode - Normal
- Display - On
- VOLTS/DIV - 10 mV/div
- OFFSET - 0 V

- Timebase - SEC/DIV - 50 us/div
- DELAY - 0 Sec
- Delay Ref at - Center screen

- Trigger - Mode - Edge
- Source - Trig 3
- LEVEL - 0 V
- Slope - Positive
- HOLDOFF Time - 70 ns

- Display - Mode - Averaged
- AVERAGES - 16
- Split Screen - Off
- Graticule - Axes

Function Generator:

- Mode - Normal
- Frequency - 1 kHz
- Offset - 0 V
- Waveform - Sinewave

Main Trigger Board (A8) Adjustment Locations



Adjustments

3-13. MAIN TRIGGER BOARD CALIBRATION ADJUSTMENTS (Continued)

Procedure:

1. Connect function generator output to both channel 1 and trigger 3 inputs.
2. Adjust sinewave amplitude for an approximate 8 division peak-to-peak displayed signal
3. Waveform should be triggered with the 0 volt crossing at approximately center screen.
4. The hysteresis (A8R3) may require adjustment to obtain triggering
5. In the Trigger menu, toggle slope repeatedly between Pos and Neg.

NOTE

The difference between voltage levels at time zero (center screen) as slope is switched is hysteresis. The actual trigger level is halfway between the two observed levels, that is, at the center of the hysteresis band.

6. Adjust A8R3 (Hysteresis adjustment) for a voltage difference (Y axis) of 10 mV (1 major division) at time zero as slope is switched.
 7. As slope is switched, adjust A8R2 (Offset), until the two voltage levels at time zero are centered above and below 0 V.
 8. Set channel 1 sensitivity to 100 mV/division and adjust the 1 kHz sinewave for approximately 8 divisions peak-to-peak.
 9. Set trigger level (channel 3) and channel 1 offset to 1.2 volts.
 10. Adjust function generator offset until sinewave is centered on screen.
 11. Adjust Level Cal (A8R1) until the voltage levels at time zero are centered around center vertical graticule (Y axis) as slope is toggled.
 12. Set trigger level (channel 3) and channel 1 offset to -1.2 volts.
 13. Adjust function generator offset to center the signal on screen and verify voltage levels at time zero are centered within two minor divisions of vertical center as slope is toggled.
-

Adjustments

3-14. FINE INTERPOLATOR CALIBRATION

Description:

Interpolator gain is adjusted for a completely smooth leading edge without any area of discontinuity.

Equipment Required:

Programmable Pulse Generator HP Model 8161A

Instrument Setup:

54110D:

- Channel 1 - Mode - Normal
- Display - On
- VOLTS/DIV - 200 mV/div
- OFFSET - -1.2 V

- Channel 2 - Mode - Normal
- Display - Off
- VOLTS/DIV - 1 V/div

- Timebase - SEC/DIV - 1 ns/div
- DELAY - 0
- Delay Ref at - Center screen
- Trg'd

- Trigger - Mode - Edge
- Source - 2
- LEVEL - 1.2V
- Slope - pos
- HOLDOFF Time - 100 ns

- Display - Mode - Normal
- DISPLAY TIME - 2 seconds
- Graticule - Axes

Pulse Generator:

- Period - 1 us
- Width - 500 ns
- Leading edge
- (LEE) - 1 ns
- Trailing edge
- (TRE) - 1 ns
- High level
- (HIL) - -0.8 V
- Low level
- (LOL) - -1.6 V
- Delay - 1 ns

Main Trigger Board (A8) Adjustment Locations



Adjustments

3-14. FINE INTERPOLATOR CALIBRATION (Continued)

Procedure:

1. Preset A8R4 (INTERP GAIN) on Main Trigger Board fully counter-clockwise (CCW).
2. Connect pulse generator output to channel 1
3. Connect pulse generator trigger output to channel 2.
4. Observe display for an area of the waveform where no data is present. Refer to figure 3-2.

NOTE

It may be necessary to adjust both the 54110D and the pulse generator delay to place the area of discontinuity in the center of the screen.

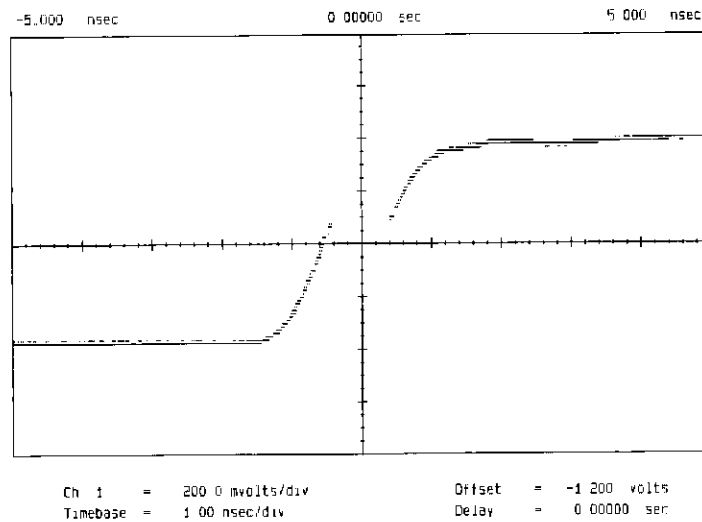

Figure 3-2. Leading edge with area of discontinuity (no data present).

Adjustments

3-14. FINE INTERPOLATOR CALIBRATION (Continued)

5. Slowly change pulse generator period in 100 ps steps until the area of discontinuity is centered vertically on the display. Refer to figure 3-3.
6. Using Timebase Delay function, move the discontinuity until it is centered on middle vertical graticule. The Timebase Delay function is obtained by selecting the Timebase menu, then DELAY function. Refer to figure 3-3.

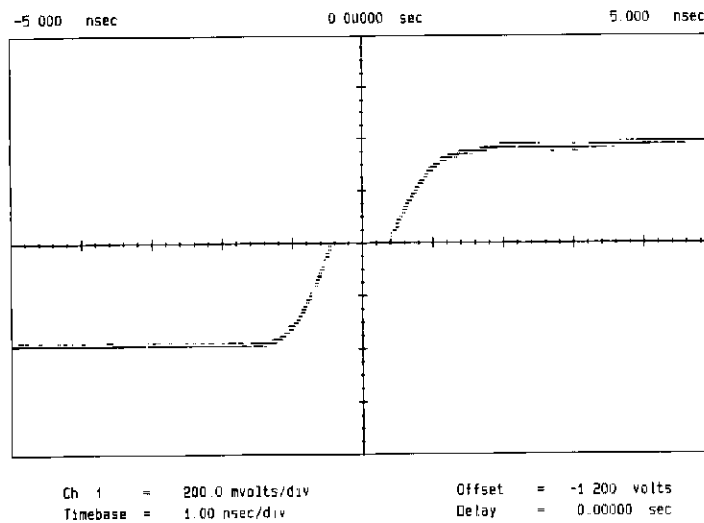

Figure 3-3. Area of discontinuity centered vertically.

Adjustments

3-14. FINE INTERPOLATOR CALIBRATION (Continued)

7. Change sweep speed to 500 ps/division.
8. Using channel 1 Vertical Magnify Mode menu, center the window and expand to 40 mV/division (Window size = 320 mV) Refer to figure 3-4.
9. Slowly adjust A8R4 (INTERP GAIN) to decrease the size of the hole in displayed waveform.

NOTE

Do not completely eliminate discontinuity at this time.

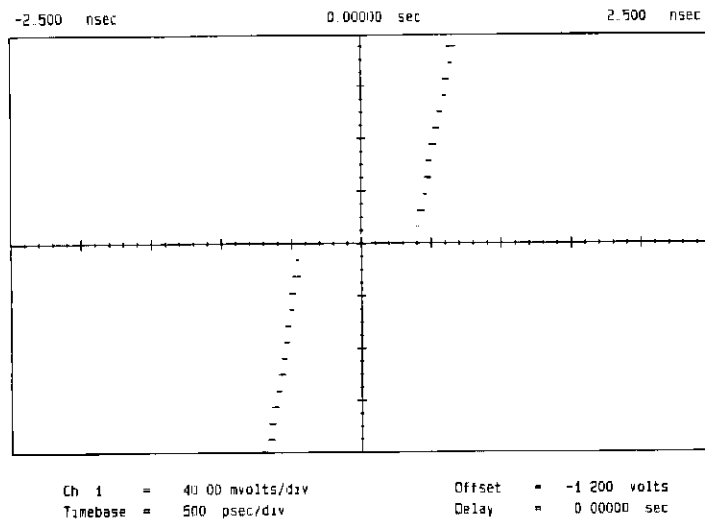

Figure 3-4. Area of discontinuity centered and expanded.

Adjustments

3-14. FINE INTERPOLATOR CALIBRATION (Continued)

10. Periodically adjust Timebase DELAY to keep the area of concern at center screen.
11. As more resolution is needed, increase sweep speed to 100 ps/division.
12. Change Display to Averages = 2048 and Graticule to Frame.
13. Continue to rotate A8R4 (INTERP GAIN) clockwise until there is no longer an area of the waveform without data.
14. Refer to figure 3-5 for desired waveform at correct adjustment. A8R4 is adjusted correctly when there is a continuous smooth trace where there once was discontinuity.

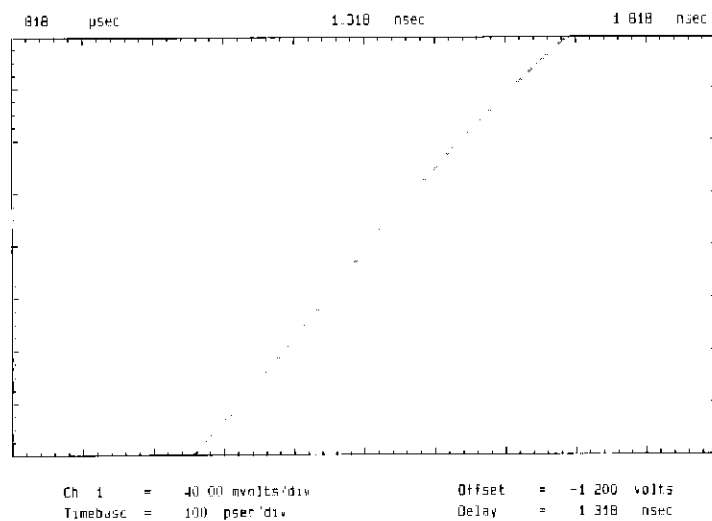

Figure 3-5 Waveform when adjustment is **correct**.

Adjustments

3-14. FINE INTERPOLATOR CALIBRATION (Continued)

NOTE

If A8R4 is not adjusted correctly but is close, the display will have a small but very observable "S" shape as shown in figure 3-6

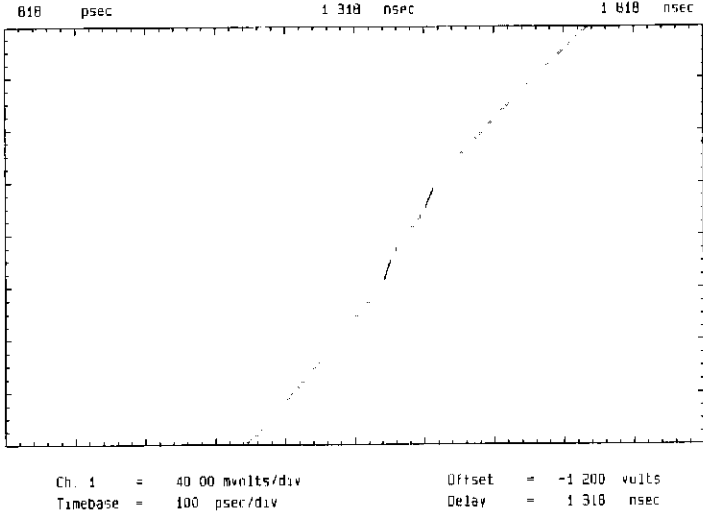

Figure 3-6. Close adjustment but not correct (note small "S" shape).

Adjustments

3-15. TRIGGER QUALIFIER CALIBRATION ADJUSTMENTS

Description:

Hysteresis, offset and trigger level are calibrated by observing the voltage level where displayed waveform crosses the zero time reference which is set to center screen.

Equipment Required:

Function Generator HP Model 8116A

Instrument Setup:

54110D:

- Channel 1 - Mode - Normal
- Display - On
- VOLTS/DIV - 10 mV/div
- OFFSET - 0 V

- Timebase - SEC/DIV - 50 us/div
- DELAY - 0 Sec
- Delay Ref at - Center screen

- Trigger - Mode - Edge
- Source - Trig 4
- LEVEL - 0 V
- Slope - Positive
- HOLDOFF Time - 100 ns

- Display - Mode - Averaged
- AVERAGES - 16
- Split Screen - Off
- Graticule - Axes

Function Generator:

- Mode - Normal
- Frequency - 1 kHz
- Offset - 0 V
- Waveform - Sinewave

Trigger Qualifier Board (A9) Adjustment Locations

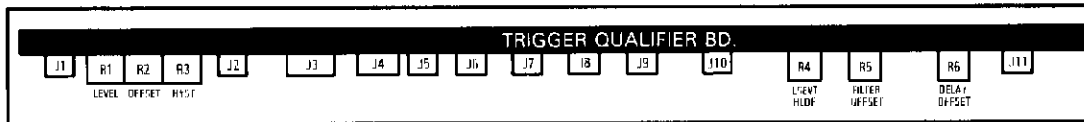

Adjustments

3-15. TRIGGER QUALIFIER CALIBRATION ADJUSTMENTS (Continued)

NOTE

The vertical sensitivity and offset must be calibrated before trigger circuits are calibrated.

Procedure:

1. Connect function generator output to both channel 1 and trigger 4 inputs
2. Adjust sinewave amplitude for an approximate 8 division peak-to-peak displayed signal
3. Waveform should be triggered with the 0 volt crossing at approximately center screen.
4. The hysteresis (A9R3) may require adjustment to obtain triggering.
5. In the Trigger menu, toggle the slope repeatedly between Pos and Neg.

NOTE

The difference between voltage levels at time zero (center screen) as slope is switched is the hysteresis. The actual trigger level is halfway between the two observed levels, that is, at the center of the hysteresis band.

6. Adjust A9R3 (Hysteresis adjustment) for a voltage difference (Y axis) of 10 mV (1 major division) at time zero as slope is switched.
7. As slope is switched, adjust A9R2 (Offset), until the two voltage levels at time zero are centered above and below 0 V.
8. Set channel 1 sensitivity to 100 mV/division and adjust the 1 kHz sinewave for approximately 8 divisions peak-to-peak.
9. Set trigger 4 and channel 1 offset to 1.2 volts

Adjustments

3-15. TRIGGER QUALIFIER CALIBRATION ADJUSTMENTS (Continued)

10. Adjust function generator offset until sinewave is centered on screen (approximately 1.2 V).
 11. Adjust Level Cal (A9R1) until voltage levels at time zero are centered above and below 0 V as slope is toggled
 12. Set trigger level and channel 1 offset to -1.2 volts.
 13. Adjust function generator offset to center signal on screen.
 14. While trigger slope is toggled, verify voltage levels at time zero are within two minor divisions of vertical center.
-

Adjustments

3-16. STARTABLE OSCILLATOR ADJUSTMENT

Description:

The oscillator is adjusted to 50 MHz

Equipment Required:

Frequency Counter HP Model 5381A
 Miniature Divider Probe HP Model 10017A

Instrument Setup:

54110D:

- Timebase - Sweep - Trg'd
- Trigger - Mode - Pattern, "XXXX When Present > 30 ns"
- HOLDOFF Time - 70 ns

Trigger Qualifier (A9) Board Adjustment Locations

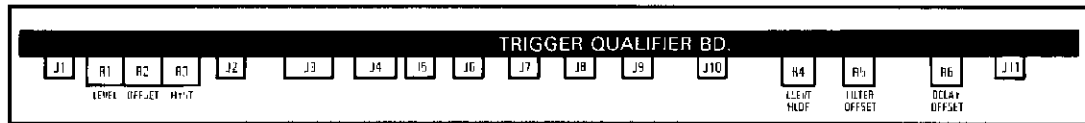

Procedure:

1. Connect frequency counter to J11 on the A9 board with miniature divider probe.
2. Adjust A9C1 (OSC CAL) for a frequency of 50 MHz ±0.02 MHz.

NOTE

J11 is located approximately one-fourth the way down the rear edge of the board and will accept the miniature probe tip.

Adjustments

3-17. FILTER TIME OFFSET ADJUSTMENT

Description:

Filter Offset is adjusted until oscilloscope will just trigger when a 20 ns pulse is applied.

NOTE

Startable Oscillator should be calibrated before the Filter Time Offset.

Equipment Required:

Programmable Pulse Generator HP Model 8161A

Instrument Setup:

54110D:

- Channel 1 - Mode - Normal
- Display - On
- VOLTS/DIV - 200 mV/div
- OFFSET - 0 V

- Channel 2 - Display - Off

- Timebase - SEC/DIV - 5 ns/div
- DELAY - 0
- Delay Ref at - Center screen
- Sweep - Trg'd

- Trigger - Mode - Edge
- Source - Chan 1
- LEVEL - 0 V
- Slope - Negative
- HOLDOFF Time - 70 ns

- Display - Mode - Normal
- DISPLAY TIME - 500 ms
- Split Screen - Off
- Graticule - Axes

- V-Markers - On
- Chan - 1
- V(1) - 0 V
- V(2) - 0 V

- T-Markers - On
- Start on Pos Edge 1
- Stop on Neg Edge 1

Pulse Generator:

- Period - 300 ns
- Width - 20.0 ns
- Delay - 0 ns (DBL off)
- High level
- (HIL) - +0.6 V
- Low level
- (LOL) - -0.6 V
- Leading edge
- (LEE) - 1 ns
- Trailing edge
- (TRE) - 1 ns
- Input Mode - Normal

Adjustments

3-17. FILTER TIME OFFSET ADJUSTMENT (Continued)

Trigger Qualifier Board (A9) Adjustment Locations

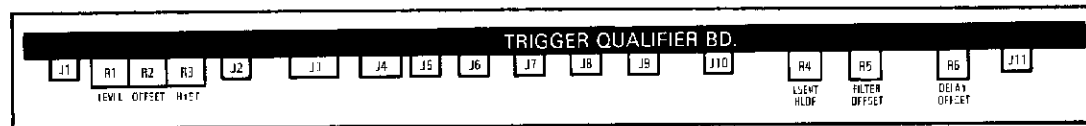

Procedure:

1. Connect pulse generator output to channel 1.

NOTE

The display should be an approximate 20 ns pulse with an amplitude of 6 divisions peak-to-peak, with the trailing edge at time zero.

2. Adjust the pulse generator width to obtain as close as possible, but just under, a 20 ns pulsewidth as measured with Precise Edge Find.

NOTE

Use Precise Edge Find and not Autoparameters to measure pulse.

3. Increment pulse generator high level (HIL) as a fine adjust to obtain a 20 ns ± 100 ps pulse width.
4. Change trigger mode to Pattern: "HXXX When Present > 20 ns".

NOTE

"When Present" is obtained by pressing the "When Entered" key twice.

5. Adjust FILTER OFFSET (A9R5) until oscilloscope just triggers. Ideally, adjustment should be right on the threshold where the scope is intermittently triggering as indicated by an increase in jitter or slowed acquisition. If necessary, change SEC/DIV to a faster setting to see these effects better.
-

Adjustments

3-18. LAST EVENT HOLDOFF ADJUSTMENT

Description:

Last Event Holdoff is adjusted for a 4 ns delay after the second to the last event before main trigger is enabled.

Equipment Required:

Programmable Pulse Generator HP Model 8161A

Instrument Setup:

NOTE

If Filter Time Adjustment (paragraph 3-17) has just been completed, setup channel 2 ONLY

54110D:

Pulse Generator:

- | | |
|--|---|
| <ul style="list-style-type: none"> Channel 1 - Mode - Normal <li style="padding-left: 20px;">- Display - On <li style="padding-left: 20px;">- VOLTS/DIV - 200 mV/div <li style="padding-left: 20px;">- OFFSET - 0 V
 Channel 2 - Mode - Normal <li style="padding-left: 20px;">- Display - On <li style="padding-left: 20px;">- VOLTS/DIV - 100 mV/div <li style="padding-left: 20px;">- OFFSET - -348 mV
 Timebase - SEC/DIV - 5 ns/div <li style="padding-left: 20px;">- DELAY - 0 V <li style="padding-left: 20px;">- Delay Ref at - Center screen <li style="padding-left: 20px;">- Trg'd
 Trigger - Mode - Edge <li style="padding-left: 20px;">- Source - Chan 1 <li style="padding-left: 20px;">- LEVEL - 0 V <li style="padding-left: 20px;">- Slope - Negative <li style="padding-left: 20px;">- HOLDOFF Test - 70 ns
 Display - Mode - Normal <li style="padding-left: 20px;">- DISPLAY TIME - 500 ms <li style="padding-left: 20px;">- Split Screen - Off <li style="padding-left: 20px;">- Graticule - Axes | <ul style="list-style-type: none"> Period - 300 ns Width - 20.0 ns Delay - 0 ns (DBL off) High level <li style="padding-left: 20px;">(HIL) - +0.6 V Low level <li style="padding-left: 20px;">(LOL) - -0.6 V Leading edge <li style="padding-left: 20px;">(LEE) - 1 ns Trailing edge <li style="padding-left: 20px;">(TRE) - 1 ns Input Mode - Normal |
|--|---|

Adjustments

3-18. LAST EVENT HOLDOFF ADJUSTMENT (Continued)

Trigger Qualifier (A9) Board Adjustment Locations

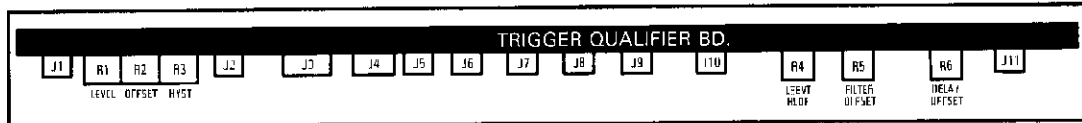

Procedure:

1. Connect pulse generator to channel 1
2. Set 54110D trigger to Pattern Mode "HXXX When Present > 20 ns".
3. Adjust pulse generator pulse width using Width and high level (HIL) until the oscilloscope is just on the threshold of triggering.
4. Set channel 1 to OFF, and channel 2 to ON.
5. Remove the cable from J10 (DOUT) on Trigger Qualifier board (A9), terminate J10 with 50 ohms and connect J10 to the channel 2 input (an external 50 Ω load is required if channel 2 does not have a 54002A 50 Ω pod installed) The Trigger should become stable.

NOTE

This 50 ohm termination may be accomplished by using an SMB to BNC Adapter and connecting to a 50 ohm load. An alternative is to use the SMB to BNC cable HP P/N 54100-61616 supplied in the product support kit HP P/N 54100-69002.

6. Set SEC/DIV to 2 ns and increase DELAY to bring leading edge of the positive pulse on channel 2 to precisely center screen.

NOTE

Do not change DELAY setting for the following steps.

7. Change 54110D trigger to Evnt-Dly and setup as follows: After [Pos] Edge, On [Chan 1], Trig On [2] Events, Of [Neg] Edge, On [Chan 1]
8. Observe positive transition on channel 2 to the right of center screen and adjust LSEVT HLDF (A9R4) to position edge as close as possible to 2 divisions (4 ns) to the right of center screen. Adjustment must be > 1.5 division (3 ns) and < 4 divisions (8 ns).

Adjustments

3-19. DELAY OFFSET ADJUSTMENT

Description:

Delay Offset is adjusted so trigger will enable on a negative pulse edge which occurs 30 ns after a positive pulse edge

NOTE

Startable Oscillator and Last Event Holdoff calibrations should be performed prior to the Delay Offset Calibration.

Equipment Required:

Programmable Pulse Generator HP Model 8161A

Instrument Setup:

54110D:

- Channel 1 - Mode - Normal
- Display - On
- VOLTS/DIV - 200 mV/div
- OFFSET - 0 V

- Timebase - SEC/DIV - 20 ns/div
- DELAY - 0
- Delay Ref at - Center screen
- Trg' -

- Trigger - Mode - Edge
- Source - Chan 1
- LEVEL - 0
- Slope - Negative
- HOLDOFF Time - 70 ns

- Display - Mode - Normal
- DISPLAY TIME - 500 ms
- Split Screen - Off
- Axes -

- V-Markers - On
- Chan - 1
- V(1) - 0 V
- V(2) - 0 V

- T-Markers - On
- Start on Pos Edge 1
- Stop on Neg Edge 1

Pulse Generator:

- Period - 300 ns
- Width - 30.0 ns
- DBL - 50 ns (Delay Off)
- High level
- (HIL) - +0.6 V
- Low level
- (LOL) - -0.6V
- Leading edge
- (LEE) - 1 ns
- Trailing edge
- (TRE) - 1 ns
- Gate - Normal

Adjustments

3-19. DELAY OFFSET ADJUSTMENT (Continued)

Trigger Qualifier Board (A9) Adjustment Locations

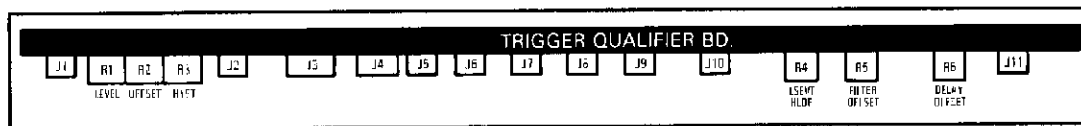

Procedure:

1. Preset DELAY OFFSET (A9R6) fully clockwise.
2. Connect pulse generator output to the channel 1 input.
3. Adjust pulse generator Width to obtain as close as possible, but just under, a 30 ns width for the first pulse as measured with Precise Edge Find.
4. Increment pulse generator high level (HIL) as a fine adjust to obtain an observed 30 ns \pm 100 ps pulse width.

NOTE

Use Precise Edge Find and not Autoparameters to measure the pulse.

5. Set 54110D trigger to Time-Dly and setup as follows: After [Pos] Edge, On [Chan 1], Delay [30 ns] Then, Trig On [Neg] Edge, On [Chan 1]. The 54110D should be triggered on the negative edge of the second pulse.
 6. Adjust DELAY OFFSET (A9R6) to the point where the scope switches from triggering on the second pulse to triggering on the first pulse. Ideally this would be the point where the scope is equally triggered on both negative edges as indicated by three pulses displayed on the CRT.
-

Adjustments

3-20. 81.669 MHZ MASTER OSCILLATOR OVERTONE TUNING

Description:

The master oscillator is adjusted to ensure the circuit operates on the fifth harmonic overtone of the crystal.

NOTE

Do not perform this procedure during routine calibration. This procedure is only necessary after oscillator circuit has been replaced.

Equipment Required:

Oscilloscope ... HP Model 1725A
50Ω Resistive Divider probe ... HP Model 10020

Instrument Setup:

- | | |
|---------|----------------------------|
| 54110D: | 1725A: |
| NONE | CHANNEL A - on |
| | CHANNEL B - off |
| | Timebase - 10 ns |
| | Sweep - Main |
| | Trigger - CHANNEL A |
| | - Internal |
| | - Slope - Positive |
| | - AC Coupled |
| | - Level 0 V |
| | Probe - HP Model 10020 |
| | - 50 ohm resistive divider |
| | - 50:1 divider tip |
| | - Spanner |

Timebase Board (A3) Adjustment Locations

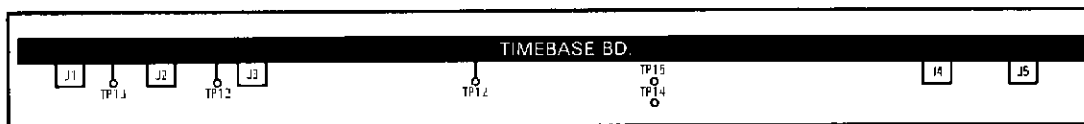

Adjustments

3-20. 81.669 MHZ MASTER OSCILLATOR OVERTONE TUNING (Continued)

Procedure:

1. Remove power cable.
2. Remove Trigger Qualifier PC Board (A9) from slot 8.
3. Move Timebase PC Board (A3) to slot 9.
4. Remove right side cover.
5. Apply power and let instrument temperature re-stabilize for approximately 10 minutes.
6. Connect 10020A probe to channel A of the monitor oscilloscope and the probe tip to A3TP1 on the 54110D Timebase Board. Connect the probe ground to the square pad above A3TP1.

NOTE

A3TP1 (round pad) and the square pad for probe ground are located on the front edge of the board midway between top and bottom.

7. Apply power to the 54110D. The monitor oscilloscope should display a sinewave of approximately 80 MHz.
8. Using a non-metallic adjustment tool, adjust A3C102 until the peak-to-peak amplitude of the oscillator sinewave is at its maximum value (≈ 600 mV).

NOTE

A3C102 is located at the bottom front of PC board below J1.

9. Restore instrument to original board configuration.
-

Adjustments

3-21. CRT COLOR MODULE ADJUSTMENTS

NOTE

DO NOT PERFORM THESE ADJUSTMENTS DURING ROUTINE CALIBRATIONS. The following procedures are provided only for the few extreme cases where either the earth's magnetic field or the user's environment cause an unusable display due to mis-convergence that cannot be corrected by degaussing the entire CRT screen

Description:

The CRT Color Module is adjusted to compensate for external magnetic influences causing mis-convergence.

NOTE

DO NOT continue this procedure before first degaussing the CRT screen using the rear panel degaussing switch. In extreme cases of magnetism, it may be necessary to degauss the CRT using a conventional external television-type degaussing coil. **During any of the following adjustments, the CRT module must face west.**

Equipment Required:

Non-metallic Adjustment Tool Sony Part Number 4-367-065-01

Procedure:

NOTE

The following adjustments are broken down in adjustment groups. The adjustment group sequence must be followed in order due to interaction and dependency. The adjustment group sequence is shown in the adjustment flow diagram in figure 3-7. There will be cases where not all the adjustments groups will be needed. For example, if the Geometry Adjustment Group corrects the problem, this will be the only group needed.

Adjustments

3-21. CRT COLOR MODULE ADJUSTMENTS (Continued)

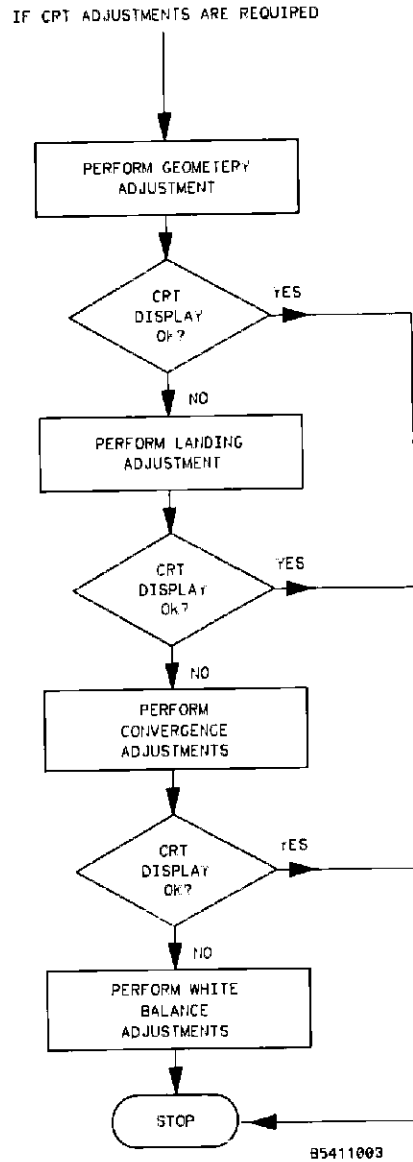

Figure 3-7. CRT Module Adjustment Flow Diagram.

Adjustments

3-21. CRT COLOR MODULE ADJUSTMENTS (Continued)

Geometry Adjustments

1. In UTILITY menu, select CRT SETUP, then select CRT PATTERN key as required until the white cross-hatch is displayed on CRT.
2. Preset front panel BACKGROUND control to mechanical center.
3. Preset front panel CONTRAST control maximum clockwise.
4. Preset H.SUB SHIFT (RV006) and V.SUB SHIFT (RV008) located on the bottom PC board to mechanical center.
5. Using a flexible ruler, adjust H.SIZE (RV504) AND V.HEIGHT (RV502) located on the left hand side PC board so that the border of the cross-hatch pattern displayed on the CRT is 120.5 mm (4 7/8 in.) vertically and 161 mm (6.34 in.) horizontally.
6. Adjust V.CENT (RV510) AND H.CENT (RV503) located on the left hand side PC board to center pattern.
7. Adjust PIN AMP (RV506) located on the left hand side PC board to eliminate pincushion distortion in the vertical lines of the cross-hatch pattern as shown in figure 3-8.

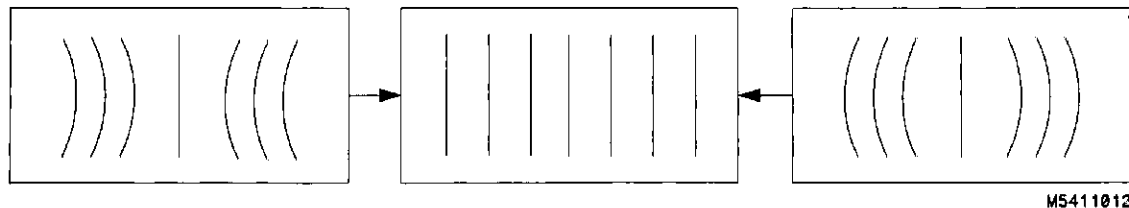

Figure 3-8. PIN AMP Adjustment.

Adjustments

3-21. CRT COLOR MODULE ADJUSTMENTS (Continued)

Geometry Adjustments (Continued)

- 8 Adjust PIN PHASE (RV505) located on the left side PC board to eliminate pin phase distortion in the vertical lines of the cross-hatch pattern as shown in figure 3-9.

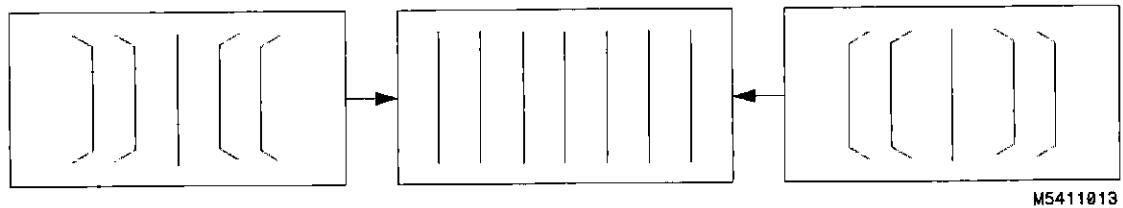

Figure 3-9. PIN PHASE Adjustment.

9. Adjust TOP PIN (RV511) located on the left hand side PC board so that top horizontal line is parallel with the center horizontal line.
 10. Adjust BOTTOM PIN (RV512) located on the left hand side PC board so that bottom horizontal line is parallel with the center horizontal line.
-

Adjustments

3-21. CRT COLOR MODULE ADJUSTMENTS (Continued)

Landing, Convergence And Focus Adjustment Preparation Procedures:

1. Remove CRT Display Module from the instrument (see section 6, paragraph 6-10).
2. Reconnect instrument front panel and re-install front panel and CRT bezel (use two screws to temporarily hold front panel in place).
3. Loosen deflection yoke clamp screw.
4. With CRT Display Module placed to the left of mainframe, reconnect module.

NOTE

Note the original routing of the module power cable for proper routing when module is re-installed in instrument. Then, re-route the module power cable from inside the module to the outside (left side) of module for reconnection to the power supply for adjustments.

5. Remove deflection yoke spacers by moving deflection yoke rearward and removing spacers.

NOTE

The deflection yoke spacers are tapered rubber blocks located between front of yoke and rear of CRT funnel.

6. Apply power and allow the instrument to thermally re-stabilize for 20 minutes
-

Focus Adjustment

NOTE

Geometry adjustments must be performed before making focus adjustment.

1. In UTILITY menu, select CRT SETUP, then select CRT PATTERN key as required until the white cross-hatch is displayed on CRT.
 2. Adjust FOCUS (RV701) located on the rear PC board for best overall focus.
-

Adjustments

3-21. CRT COLOR MODULE ADJUSTMENTS (Continued)

Landing Adjustment

1. In UTILITY menu, select CRT SETUP, then select COLOR PURITY key as required until a white raster is displayed on CRT.
2. Turn front panel CONTRAST control fully clockwise
3. Degauss entire CRT screen by pressing momentary DEGAUSSING switch located on the instrument rear panel.

NOTE

In cases where the user's environment or shipping environment has caused high levels of magnetization to take place, it may be necessary to externally degauss the CRT using a conventional television type degaussing coil to completely degauss the CRT

4. Set purity magnet tabs to mechanical center (see figure 3-10).

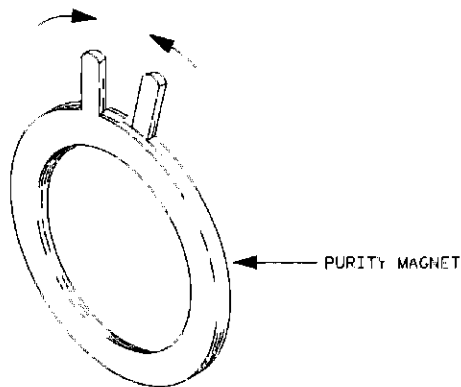

M5411001

Figure 3-10. Purity Magnet Centering.

5. Select COLOR PURITY key as required until a green raster is displayed on CRT.

Adjustments

3-21. CRT COLOR MODULE ADJUSTMENTS (Continued)

Landing Adjustment (Continued)

6. Move deflection yoke rearward until left edge of raster turns red and right side of raster turns blue (see figure 3-11)

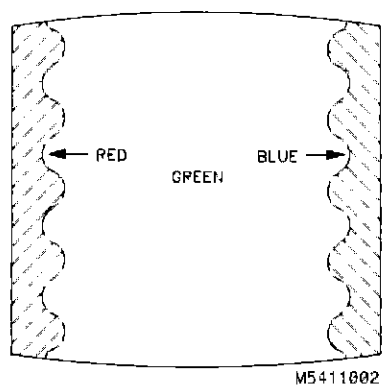

Figure 3-11. Purity Magnet Adjustment Raster

7. Adjust purity magnets until green is in center of raster with red and blue bands evenly distributed on the sides (see figure 3-11).
8. Move deflection yoke forward until entire raster is green.

NOTE

Landing adjustment is easier if yoke is moved all the way forward and then moved back until raster is completely green.

9. Using COLOR PURITY key, replace green raster with red and then blue rasters each time checking for proper landing adjustment (color purity of each).

Adjustments

3-21. CRT COLOR MODULE ADJUSTMENTS (Continued)

Landing Adjustment (Continued)

- 10 If landing is not correct in step 9, repeat steps 6 through 9 for best compromise (see figure 3-12)

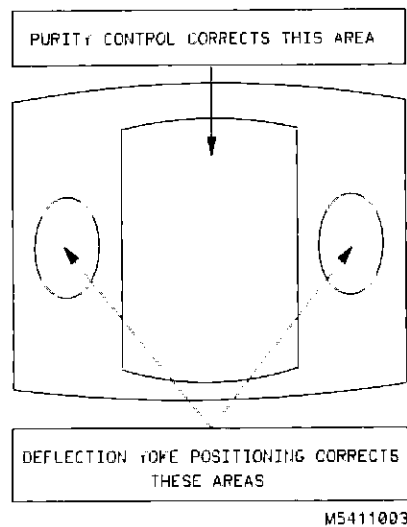

Figure 3-12. Landing and Purity Adjustment Guide.

11. If landing is not correct in step 10, readjust purity magnets for best landing of each color
12. When landing adjustment is complete, tighten deflection yoke clamp screw just enough to keep yoke from moving. **DO NOT over tighten.**

NOTE

While moving deflection yoke forward and rearward, rotate yoke as necessary to make vertical edges of raster parallel to the sides of the instrument frame.

Adjustments

3-21. CRT COLOR MODULE ADJUSTMENTS (Continued)

Static Convergence

1. Preset front panel BACKGROUND control to mechanical center.
2. Preset front panel CONTRAST control maximum clockwise
3. Temporarily disconnect power from instrument and remove PC board shield cover from rear of CRT Display module by prying evenly on all four sides
4. Re-apply power and using UTILITY menu, select CRT PATTERN key as necessary to obtain the white cross-hatch pattern.
5. Check the four dots which are located around the center intersection of the cross-hatch pattern for coincidence of the blue, red and green dots. If the dots are not coincident, adjust H.STAT (RV703) located on the rear PC board to obtain horizontal coincidence and V.STAT (RV803) located on the bottom PC board to obtain vertical coincidence (see figure 3-13).

NOTE

Due to interaction, BEAM LANDING will need to be re-adjusted if either HSTAT or VSTAT adjustments are made. Once BEAM LANDING is re-adjusted, repeat step 5 above if necessary to obtain center screen coincidence of the dots.

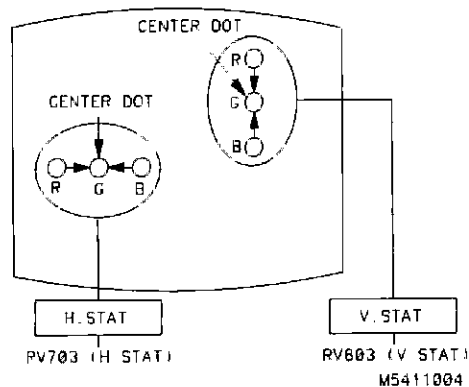

Figure 3-13 Static Convergence.

Adjustments

3-21. CRT COLOR MODULE ADJUSTMENTS (Continued)

Dynamic Convergence

1. Using UTILITY menu, select CRT PATTERN key as necessary to obtain the white cross-hatch pattern.
2. Adjust Y BOW (RV805) located on the bottom PC board to eliminate red, green and blue bowing at the top and bottom of the center vertical line (see figure 3-14).

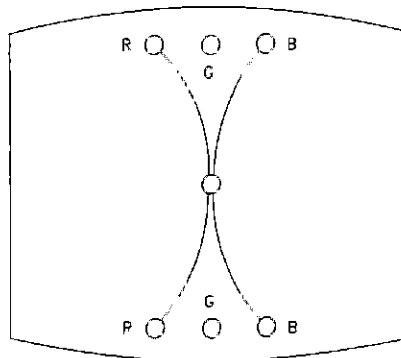

M5411005

Figure 3-14. Y BOW Adjustment

3. Adjust Y BOW CROSS (RV804) located on the bottom PC board to eliminate red, green and blue orthogonal mis-alignment at the top and bottom of the center vertical line (see figure 3-15)

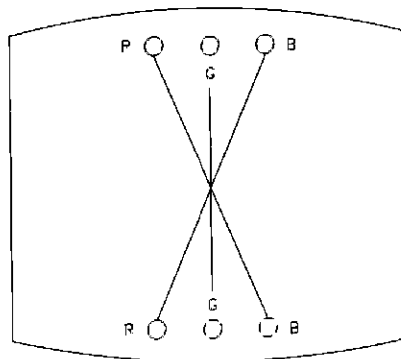

M5411006

Figure 3-15. Y BOW CROSS Adjustment.

Adjustments

3-21. CRT COLOR MODULE ADJUSTMENTS (Continued)

Dynamic Convergence (Continued)

4. Adjust V.STAT TOP (RV801) and V.STAT BOTTOM (RV802) located on the bottom PC board to obtain coincidence of the red, blue and green at the intersection of the top and bottom horizontal lines with the center vertical line (see figures 3-16 and 3-17).

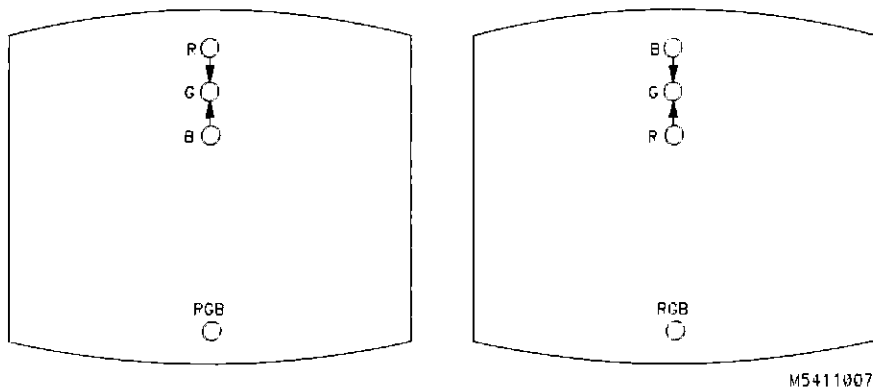

Figure 3-16. V.STAT TOP Adjustment

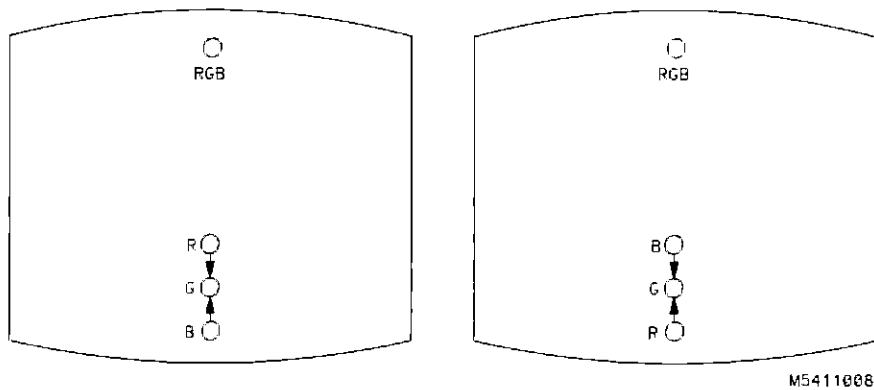

Figure 3-17. V.STAT BOTTOM Adjustment

Adjustments

3-21. CRT COLOR MODULE ADJUSTMENTS (Continued)

Dynamic Convergence (Continued)

- Adjust H.AMP (RV807) located on the bottom PC board for equal amounts of mis-convergence at right and left sides of screen (see figure 3-18).

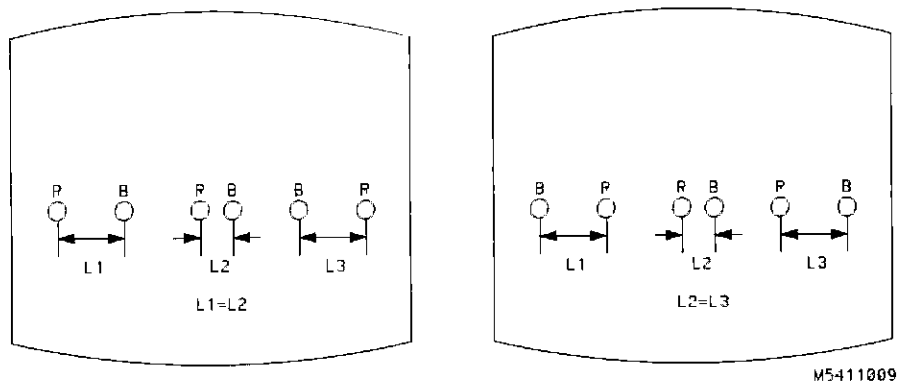

Figure 3-18. H.AMP Adjustment.

- Adjust H.TILT (RV806) located on the bottom PC board for coincidence of red, green and blue at right and left sides of screen (see figure 3-19)

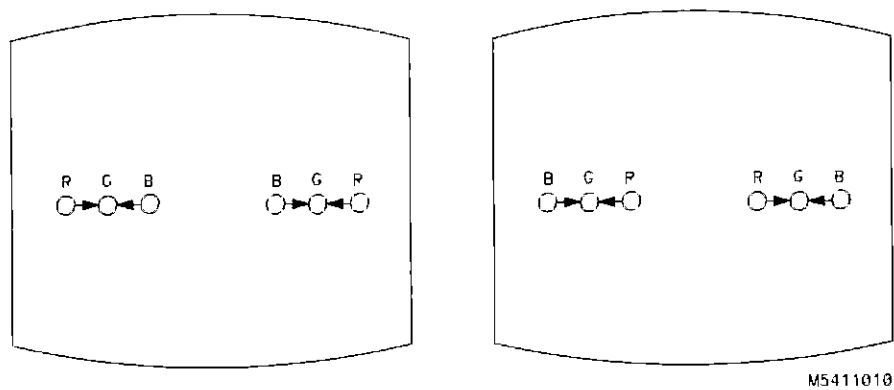

Figure 3-19. H.TILT Adjustment.

Adjustments

3-21. CRT COLOR MODULE ADJUSTMENTS (Continued)

White Balance

1. Using UTILITY menu, select LIGHT OUTPUT key as necessary to obtain a blanked raster.

NOTE

The completely blanked raster will contain the text for the function keys on the right side of the display, however, this will not affect the adjustment.

2. Set front panel BACKGROUND and SUB BRT (RV901) located on the bottom PC board to mechanical center.
3. Set front panel BRIGHTNESS and SUB CONT (RV902) located on the bottom PC board to mechanical center.
4. Set G. DRIVE (RV921), B. DRIVE (RV931) and R. DRIVE (RV911) located on the bottom PC board to mechanical center.
5. Set G. BKG (RV721), B. BKG (RV731) and R. BKG (RV711) located on the rear PC board fully counterclockwise (CCW).
6. Adjust the SCREEN (RV702) located on the rear PC board until either red, green or blue raster just starts to become visible. Note which color becomes visible first and do not adjust the background control (BKG) for that color in the next step.
7. Adjust the other two background controls for best white balance.
8. Using UTILITY menu, select COLOR PURITY key as necessary to obtain the white raster.
9. Set front panel BRIGHTNESS control at maximum.
10. Observe the screen and adjust the DRIVE controls (RV921, RV931 and RV911) located on the bottom PC board for best white balance.

NOTE

White balance is checked in two ways. First, using an average piece of white photocopy paper, compare the white on the CRT to the paper. Second, in the CONFIDENCE TEST function, the gray scale blocks are checked to make sure the block at the far left of the CRT is visible.

11. Repeat steps 1-3 and 6-10 until satisfied with white balance.
-



SECTION IV

REPLACEABLE PARTS

4-1. INTRODUCTION

This section contains information for ordering parts. Table 4-1 lists abbreviations used in the parts list, table 4-2 lists all replaceable parts in reference designator order.

4-2. ABBREVIATIONS

Table 4-1 lists abbreviations used in the parts list, the schematics, and throughout the manual. In some cases, two forms of the abbreviations are used, one all in capital letters, and one partial or no capitals. This occurs because the abbreviations in the parts list are always all capitals. However, in other parts of the manual other abbreviation forms are used with both lower and uppercase letters.

4-3. REPLACEABLE PARTS LIST

Table 4-2 is the list of replaceable parts and is organized as follows:

- a. Electrical assemblies in alphanumerical order by reference designation.
- b. Chassis-mounted parts in alphanumerical order by reference designation.
- c. Electrical assemblies and their components in alphanumerical order by reference designation.

The information given for each part consists of the following:

- a. Complete reference designation
- b. Hewlett-Packard part number.
- c. Total quantity (Qty) in instrument.
- d. Description of part.
- e. Check digit.

The total quantity for each part is only given once - at the first appearance of the part number in the list.

4-4. ORDERING INFORMATION

To order a part listed in the replaceable parts table, quote the Hewlett-Packard part number, check digit, indicate the quantity required, and address the order to the nearest Hewlett-Packard office.

Exchange assemblies are available for repair when a repairable assembly can be returned to Hewlett-Packard. These assemblies are identified by the 695 in the first three digits of the part number suffix (-695xx). If a repairable assembly is not returned to Hewlett-Packard, the cost difference between a new and exchange assembly will be billed. If additional assemblies are required for stock and returnable assemblies are not available, a new assembly must be ordered (part number suffix -665xx).

To order a part that is not listed in the replaceable parts table, include the instrument model number, instrument serial number, the description and function of the part, and number of parts required. Address the order to the nearest Hewlett-Packard office.

4-5. DIRECT MAIL ORDER SYSTEM

Within the USA, Hewlett-Packard can supply parts through a direct mail order system. Advantages of using the system are as follows:

- a. Direct ordering and shipment from HP Parts Center in Mountain View, California.
- b. No maximum or minimum on any mail order (there is a minimum order amount for parts ordered through local HP offices when orders require billing and invoicing).
- c. Prepaid transportation (there is a small handling charge for each order).
- d. No invoices - to provide these advantages, check or money order must accompany each order.

Mail order forms and specific ordering information are available through your local HP offices.

Table 4-1. Reference Designators and Abbreviations

REFERENCE DESIGNATORS			
A	=assembly	F	=fuse
B	=fan, motor	FL	=filter
BT	=battery	H	=hardware
C	=capacitor	J	=electrical connector (stationary portion) jack
CR	=diode, diode thyristor, varactor	L	=coil, inductor
DL	=delay line	MP	=misc. mechanical part
DS	=diode, diode lamp, LED	P	=electrical connector (movable portion), plug
E	=misc. electrical part	Q	=transistor, SCR triode thyristor
		R	=resistor
		RT	=thermistor
		S	=switch, jumper
		T	=transformer
		TB	=terminal board
		TP	=test point
		U	=integrated circuit, microcircuit
		V	=electron tube, glow lamp
		VR	=voltage regulator, breakdown diode
		W	=cable
		X	=socket
		Y	=crystal unit, piezo- electric or quartz

ABBREVIATIONS			
A	=amperes	DWL	=dowel
A/D	=analog-to-digital	ECL	=emitter coupled logic
AC	=alternating current	ELAS	=elastomeric
ADJ	=adjustment	EXT	=external
AL	=aluminum	F	=farad, metal film (resistor)
AMPL	=amplifier	FC	=carbon film composition
ANLG	=analog	FD	=feed
ANSI	=American National Standards Institute	FEM	=female
ASSY	=assembly	FF	=flip-flop
ASTIG	=astigmatism	FL	=flat
ASYNCHRO	=asynchronous	FM	=foam foam
ATTEN	=attenuator	FR	=front
AWG	=American wire gauge	FT	=front and width product
BAL	=balance	FW	=full wave
BCD	=binary-coded decimal	FXD	=fixed
BD	=board	GEN	=generator
BFR	=buffer	GND	=grounded
BIN	=binary	GP	=general purpose
BRDG	=bridge	GRAT	=graticule
BSHG	=brushing bandwidth	GRV	=gruicve
BW	=bandwidth	H	=Henries, high
C	=ceramic, ceramic resistor	HD	=hardware
CAL	=calibrate, calibration	HDND	=hardened
CC	=carbon composition	HG	=height
CCW	=counter-clockwise	HLCL	=helical
CER	=ceramic	HORIZ	=horizontal
CFM	=cubic feet/minute	HP	=Hewlett-Packard
CH	=chisel	HP-IB	=Hewlett-Packard Interface Bus
CHAM	=chamfered	HR	=hours
CHAN	=channel	HV	=high voltage
CHAR	=character	HZ	=Hertz
GM	=centimeter	I/O	=input-output
CMOS	=complementary metal- oxide-semiconductor	IC	=integrated circuit
GMR	=common mode rejection	ID	=inside diameter
CNDCT	=conductor	IN	=inch
CNTR	=counter	INCL	=included
CON	=connector	INCAND	=incandescent
CONT	=contact	INP	=input
GRT	=cathode-ray tube	INTEN	=intensity
CW	=clockwise	INTL	=internal
D	=diameter	INV	=inverter
D/A	=digital-to-analog	JFET	=junction field- effect transistor
DAC	=digital-to-analog converter	JKT	=jacket
DARL	=Darlington	K	=kilo (10 ³)
DAT	=data	L	=loft
DBL	=double	LB	=pound
DBM	=decibel referenced to 1mW	LCH	=latch
DC	=direct current	LCL	=lens
DCCR	=decoder	LED	=light-emitting diode
DEG	=degree	LQ	=long
DEMUX	=demultiplexer	LI	=lithium
DET	=detector	LB	=lock
DIA	=diameter	LBWR	=lock washer
DIP	=dual in-line package	LS	=low power Schottky
DIV	=division	LV	=low voltage
DMA	=direct memory access	M	=mega (10 ⁶) megahm, meter, distance
DPDT	=double pole, double throw	MACH	=machine
DRC	=DAC refresh controller	MAX	=maximum
DRVR	=driver		
		MFR	=manufacturer
		MICPROC	=microprocessor
		MINTR	=miniature
		MISC	=miscellaneous
		MLD	=molded
		MM	=millimeter
		MO	=metal oxide
		MTG	=mounting
		MTLG	=metallic
		MUX	=multiplexer
		MW	=milliwatt
		N	=north (10-3)
		NC	=no connection
		NMOS	=n-channel metal- oxide-semiconductor
		NPN	=negative-positive- negative
		NPRN	=neoprene
		NRFR	=not recommended for field replacement
		NSR	=not separately replaceable
		NUM	=numeric
		OED	=order by description
		OCTL	=cutal
		OD	=outside diameter
		OP AMP	=operational amplifier
		OSC	=oscillator
		P	=plastic
		P/O	=part of
		PC	=printed circuit
		PCB	=printed circuit board
		PD	=power dissipation
		PF	=picofarads
		PI	=plug in (labeled)
		PLA	=programmable logic array
		PLST	=plastic
		PNP	=positive-negative- positive
		POLYE	=polyester
		POS	=positive, position
		POT	=potentiometer
		POZI	=positive
		PP	=peak-to-peak
		PPM	=parts per million
		PRCN	=precision
		PREAMP	=preamplifier
		PRGMBL	=programmable
		PRL	=parallel
		PROG	=programmable
		PSTN	=position
		PT	=point
		PW	=pitch wire-wound
		PWR	=power
		R-S	=read-only
		RAM	=random-access memory
		RECT	=rectifier
		RET	=retainer
		RF	=radio frequency
		RGLTR	=regulator
		RGTR	=register
		RK	=rack
		RMS	=root-mean-square
		RND	=round
		ROM	=read-only memory
		RPQ	=rotary pulse generator
		RX	=receiver
		S	=seconds (time)
		SCR	=silicon controlled rectifier
		SEC	=second (time), secondary
		SEG	=segment
		SEL	=selector
		SGL	=single
		SHF	=shift
		SI	=silicon
		SIP	=single in-line package
		SKT	=skirt
		SL	=slide
		SLDR	=solder
		SLT	=slot (diode)
		SOLD	=sold
		SPGL	=special
		SQ	=square
		SREG	=shift register
		SREQ	=service request
		STAT	=static
		STD	=standard
		SYNCHRO	=synchronous
		TA	=tantalum
		TBAX	=tube axial
		TC	=temperature coefficient
		TD	=time delay
		THD	=thru (diode)
		THK	=thick
		THRU	=through
		TP	=test point
		TPG	=tapping
		TPL	=triple
		TRANS	=transformer
		TRIG	=trigger (diode)
		TRMR	=trimmer
		TRN	=turns
		TTL	=transistor-transistor
		TX	=transmitter
		U	=micro (10 ⁻⁶)
		UL	=Underwriter's Laboratory
		UNREG	=unregulated
		VA	=volt, ac
		VAC	=volt, ac
		VAR	=variable
		VCO	=voltage-controlled oscillator
		VDC	=volt, dc
		VERT	=vertical
		VF	=voltage, filtered
		VS	=versus
		W	=with
		W/	=with
		W/O	=without
		WW	=wire-wound
		XSTR	=extrinsic
		ZNR	=zener
		°C	=degree Celsius
		°C	(Centigrade)
		°F	=degree Fahrenheit
		°K	=degree Kelvin

HP 54110D - Replaceable Parts

Table 4-2. Replaceable Parts

Reference Designator	HP Part Number	C D	Qty	Description	Mfr Code	Mfr Part Number
A1	54110-66501	6	1	BD ASSY I/O	28480	54110-66501
A2	54100-66518	3	1	BD ASSY MICROP	28480	54110-66518
A3	54100-66508	1	1	BD ASSY TIMEBASE	28480	54110-66508
A4	54100-66509	2	2	BD ASSY SMPLG	28480	54110-66509
A5	54100-66507	0	2	BD ASSY ADC	28480	54100-66507
A6	54100-66509	2		BD ASSY SMPLG	28480	54100-66509
A7	54100-66507	0		BD ASSY ADC	28480	54100-66507
A8	54100-66511	6	1	BD ASSY MAIN TRIG	28480	54100-66511
A9	54100-66514	1	1	BD ASSY TRG QUAL	28480	54100-66514
A10	54110-66505	0	1	BD ASSY DISPLAY (does not include connector header (E2) or connector guide (E3). Re-use or order separately.)	28480	54110-66505
A11	54110-66504	9	1	BD ASSY ANAL PWR SUP	28480	54110-66504
A12	54110-66507	2	1	BD ASSY ANAL PWR SUP	28480	54110-66507
A13	54110-66506	1	1	BD ASSY DIGI PWR SUP	28480	54110-66506
A14	54110-66503	8	1	BD ASSY MOTHER	28480	54110-66503
A15	54100-66505	8	1	BD ASSY FP CONTROL	28480	54100-66505
A16	54110-66502	7	1	BD ASSY SOFT KEYS	28480	54110-66502
A17	54100-66520	7	1	BD ASSY MENU	28480	54100-66520
A18	54110-66509	4	1	BD ASSY CRT CONTROL	28480	54110-66509
A19	2090-0092	3	1	MODULE - COLOR CRT MONITOR	28480	2090-0092
A20	01980-61062	5	1	ASSY - RP6	28480	01980-61062
* EXCHANGE ASSEMBLIES (SEE PARAGRAPH 4-4 FOR EXCHANGE ASSEMBLY ORDERING INFORMATION)						
*A1	54110-69501	2	1	BD ASSY I/O	28480	54110-69501
*A2	54100-69518	3	1	BD ASSY MICROP	28480	54100-69518
*A3	54100-69508	1	1	BD ASSY TIMEBASE	28480	54100-69508
*A4	54100-69509	2	2	BD ASSY SMPLG	28480	54100-69509
*A5	54100-69507	0	2	BD ASSY ADC	28480	54100-69507
*A6	54100-69509	2		BD ASSY SMPLG	28480	54100-69509
*A7	54100-69507	0		BD ASSY ADC	28480	54100-69507
*A8	54100-69511	6	1	BD ASSY MAIN TRIG	28480	54100-69511
*A9	54100-69514	1	1	BD ASSY TRG QUAL	28480	54100-69514
*A10	54110-69505	0	1	BD ASSY DISPLAY (does not include connector header (E2) or connector guide (E3). Re-use or order separately.)	28480	54110-69505
*A12	54110-69507	2	1	BD ASSY ANAL PWR SUP	28480	54110-69507
*A13	54110-69506	1	1	BD ASSY DIGI PWR SUP	28480	54110-69506
B1	3160-0377	7	2	FAN - TRA- 122 CFM 9.5-14VDC 16.5KV-DIEL	28480	3160-0377
EXTERNAL PARTS						
E4	8160-0203	3	8††	GASKET MHTL - RFI	28480	8160-0203
NP1	0370-3033	0	1	KNOB - APC	28480	0370-3033
NP10	1460-1345	5	2	TILT STAND SST	28480	1460-1345
NP19	3160-0092	1	2	FINGER GUARD	28480	3160-0092
NP21	5001-0441	2	2	TRAIN STRIP - SIDE	28480	5001-0441
NP25	5040-7201	8	2	FOOT - BOTTOM	28480	5040-7201
NP26	5040-7202	9	1	TRAIN STRIP - TOP	28480	5040-7202
NP27	5041-6819	4	1	CAP - STRAP HNDL	28480	5041-6819
NP28	5041-6820	7	1	CAP - STRAP HNDL	28480	5041-6820
NP29	54110-40502	3	4	FOOT - REAR PANEL	28480	54110-40502
NP30	5040-7222	3	2	FOOT - HOH SHID	28480	5040-7222
NP31	5060-9805	4	1	STRAP - HANDLE	28480	5060-9805
NP32	5061-9523	5	1	CVR - PERF RT SIDE	28480	5061-9523
NP33	5060-9948	6	1	CVR - PERF LF SIDE	28480	5060-9948
NP35	54110-00201	5	1	PANEL - REAR	28480	54110-00201
NP36	54110-00202	6	1	PANEL - SYS CONTROL	28480	54110-00202
NP46	54110-04101	2	1	CVR - FAN	28480	54110-04101
NP47	54110-04103	4	1	CVR - TOP	28480	54110-04103
NP51	54110-40501	2	1	BEZEL - CRT	28480	54110-40501

See introduction to this section for ordering information

Table 4-2. Replaceable Parts (Cont'd)

Reference Designator	HP Part Number	C D	Qty	Description	Mfr Code	Mfr Part Number
W14	8120-0696	4	1	PWR CORD (Option 901)	28460	8120-0696
	8120-0698	6		PWR CORD (Option 904)	28480	8120-0698
	8120-1521	6		PWR CORD 7.5 FT (USA Only)	28480	8120-1521
	8120-1692	2		PWR CORD (Option 902)	28460	8120-1692
	8120-1703	6		PWR CORD (Option 900)	28460	8120-1703
	8120-2296	4		PWR CORD (Option 906)	28460	8120-2296
	8120-2957	4		PWR CORD (Option 912)	28460	8120-2957
PROBE/PODS						
	54001A			Order 54001-69001	28480	54002A
	54002A			50 OHM PROBE		
	54003A			Order 54003-69001		
* EXCHANGE PROBES						
	*54001-69001	5		1 GHz ACTIVE PROBE	28480	54001-69001
	*54003-69001	7		1 NEG OHM ACTIVE PROBE	28480	54003-69001
KEY CAPS						
	5041-0268	5	7	KEY CAP - BLANK (System Control)	28480	5041-0268
	5041-0400	7	14	KEY CAP - BLANK (Menu and Function)	28480	5041-0400
	5041-0906	8	1	KEY CAP - "0" (zero)	28480	5041-0906
	5041-0907	9	1	KEY CAP - "1"	28480	5041-0907
	5041-0908	0	1	KEY CAP - "2"	28480	5041-0908
	5041-0909	1	1	KEY CAP - "3"	28460	5041-0909
	5041-0910	4	1	KEY CAP - "4"	28460	5041-0910
	5041-0911	5	1	KEY CAP - "5"	28480	5041-0911
	5041-0912	6	2	KEY CAP - "6" (for 6 and 9)	28460	5041-0912
	5041-0913	7	1	KEY CAP - "7"	28460	5041-0913
	5041-0914	8	1	KEY CAP - "8"	28480	5041-0914
	5041-0984	2	1	KEY CAP - "CLEAR"	28480	5041-0984
	5041-2942	6	1	KEY CAP - "usec"	28480	5041-2942
	5041-2943	7	1	KEY CAP - "nsec"	28460	5041-2943
	5041-2944	8	1	KEY CAP - "psec"	28480	5041-2944
	5041-2945	9	1	KEY CAP - "msec/mV"	28460	5041-2945
	5041-2946	0	1	KEY CAP - "sec/Volt"	28480	5041-2946
	5041-4547	1	2	KEY CAP - CURSOR ARROWS	28460	5041-4547
	5041-4548	2	1	KEY CAP - " "	28460	5041-4548
	5041-4549	3	1	KEY CAP - "-"	28460	5041-4549
INTERNAL PARTS						
E1	54100-67601	7	4	PROBE POD INTERFACE CONN w/Cable	28480	54100-67601
E2	1252-1157	6	2	CONNECTOR HEADER	28480	1252-1157
E3	54110-40503	4	1	CONNECTOR - GUIDE	28460	54110-40502
MP2	0403-0499	7	10	GUIDE - PC BD STEEL 032-IN-BD-THKNS	28480	0403-0499
MP3	0403-0500	1	8	GUIDE - PC BD STEEL 032-IN-BD-THKNS	28480	0403-0500
MP4	1400-0611	0	1	CLAMP - CABLE	28480	1400-0611
MP5	1400-0679	0	3	CLAMP - CABLE	28480	1400-0679
MP6	1400-1122	0	1	TIE DOWN - CABLE	28460	1400-1122
MP7	54100-25701	0	4	HUT - HOUSING	28480	54100-25701
MP8	54100-45201	7	4	PROBE GUIDE	28480	54100-45201
MP9				NOT ASSIGNED		
MP11	54110-01211	9	1	PC BD RETAINER BKT	28480	54110-01211
MP12	54110-01212	0	1	PC BD RETAINER BKT SUPPORT	28460	54110-01212
MP13-18				NOT ASSIGNED		
MP20				NOT ASSIGNED		
MP22-24				NOT ASSIGNED		
MP34	54110-00101	4	1	DECK - MAIN	28460	54110-00101
MP37	54110-00203	7	1	PANEL - SUB FRM	28480	54110-00203
MP38	54110-05201	5	1	DEFL ASSY - AIR	28480	54110-05201
MP39	54110-01201	7	1	BKT - CRT TOP	28480	54110-01201
MP40	54110-01202	8	1	BKT - CRT BOT	28480	54110-01202
MP41	54110-01204	0	1	DIVIDER - FRN	28480	54110-01204
MP42	54110-01205	1	1	BKT - CARD CAGE FRM	28480	54110-01205
MP43	54110-01208	4	1	BKT - SUPPORT (Analog PWR Sup)	28480	54110-01208
MP44	54110-01209	5	1	BKT - SUPPORT (Dig PWR Sup)	28480	54110-01209
MP45	54110-01210	8	1	BKT - DISP MOD (Frame mounted)	28480	54110-01210
MP48	54110-04105	6	1	CVR - PWR SUPP (Top)	28460	54110-04105
MP49	54110-04106	7	1	CVR - PWR SUPP (Side)	28480	54110-04106
MP50	54110-04702	9	1	BKT - DISP MOD (Module mounted)	28460	54100-04702

See introduction to this section for ordering information

HP 54110D - Replaceable Parts

Table 4-2. Replaceable Parts (Cont'd)

Reference Designator	HP Part Number	C D	Qty	Description	Mfr Code	Mfr Part Number
NP50	5021-5807	0	1	FRAME - FRONT	28480	5021-5807
NP52	5021-5808	7	1	FRAME - L/R	28480	5021-5808
NP54	5021-5836	-	4	STRUT - SIDE	28480	5021-5838
NP55	0402-0092	6	1	RUBBER BUMPER (Disp Mod support)	28480	0402-0092
S1	3101-2826	-	1	SWITCH - ROCKER (Standby)	28480	3101-2826
W1	54100-61601	3	1	CABLE - PANEL	28480	54100-61601
W2	54100-61609	2	1	CABLE - HP/IB	28480	54100-61609
W3	54100-61604	6	10	CABLE - RF	28480	54100-61604
W4	54100-61610	6	2	CABLE - CHL	28480	54100-61610
W5	54100-61612	6	2	CABLE - INT PMP (AC Bd to Anal & Dig Bd)	28480	54100-61612
W6	54100-61613	9	1	CABLE - OPT HLDF	28480	54100-61613
W7	54100-61614	0	3	CABLE - RF	28480	54100-61614
W8	54110-61601	5	1	CABLE - DISP MOD PWR	28480	54110-61601
W9	54110-61602	6	1	CABLE - STB+ (PWR switch)	28480	54110-61602
W10	54110-61610	8	1	CABLE - POWER	28480	54110-61610
W11	54100-61611	7	1	CABLE - BRIGHT CONT	28480	54110-61611
W12	54110-61607	-	1	CABLE - VIDEO	28480	54110-61607
W13	54110-61608	-	1	CABLE - FRI	28480	54110-61608

See introduction to this section for ordering information



SECTION V

MANUAL CHANGES

5-1. INTRODUCTION

This section normally contains information for adapting this manual to instruments for which the content does not apply directly. Since this manual does apply directly to instruments having serial numbers listed on the title page, no change information is given here. Refer to **INSTRUMENTS COVERED BY MANUAL** in Section 1 for additional important information about serial number coverage.



SECTION VI

SERVICE

6-1. INTRODUCTION

This section contains assembly removal and replacement procedures, Service Menu familiarization, internal diagnostics(Self-Tests), and troubleshooting information for fault locating to the PC board level. Service Menu familiarization and Self-Tests/Troubleshooting are organized into two sub-sections to provide quicker access to the needed information.

Section 6A - SERVICE MENUS/KEYS

This section describes the Service menus and keys that are available to service personnel for calibration, troubleshooting and CRT alignment. A basic understanding of these will be helpful in troubleshooting failures, however, Self-Test and Troubleshooting is covered specifically in Section 6B.

Section 6B - SELF-TESTS/TROUBLESHOOTING

This section describes the Self-Tests and Troubleshooting routines that service personnel can use to locate failures to the PC board level. A basic understanding of the Service Menus and Keys will be helpful in troubleshooting failures and is covered specifically in Section 6A.

6-2. SERVICE TEST EQUIPMENT REQUIRED

Equipment required for service is listed in table 6-1. Any equipment that satisfies critical specifications given in the table may be substituted.

6-3. SAFETY CONSIDERATIONS

The following warnings and cautions must be followed for your protection and to avoid damage to the equipment

WARNING

This instrument is equipped with a standby switch on the front panel that DOES NOT de-energize the power supply. To avoid shock hazards capable of causing injury or death, the main power switch on the rear panel must be used to de-energize the instrument or the power cable must be disconnected when the instrument must be de-energized.

WARNING

Maintenance described in this section is performed with power supplied to the instrument and with protective covers removed. Maintenance should be performed only by trained service personnel who are aware of the hazards involved (for example, fire and electrical shock). Where maintenance can be performed without power applied, the power should be removed. Read the Safety Summary in the front of this manual.

CAUTION

Do not remove or replace any of the circuit board assemblies in the instrument unless instrument power is removed. The boards contain components which may be damaged if the board is removed or replaced when instrument power is applied.

Table 6-1. Recommended Service Test Equipment.

INSTRUMENT	CRITICAL SPECIFICATIONS	RECOMMENDED MODEL
Signature Multimeter	HP-IB Controllable, with DVM Range: -50V to +50V DC Accuracy: $\pm 0.01\%$	HP Model 5005B
Digital Voltmeter	>0.3% accuracy at 1 Vdc	HP Model 3478A
Oscilloscope	Dual channel 5 ns sweep with X10 magnification	HP Model 1725A
Product Support Kit	No substitute	HP Part No. 54100-69002

Assembly Removal And Replacement Procedures

6-4. CARD CAGE PC BOARDS

BOARD REMOVAL

1. Disconnect power cable.
2. Remove top cover.
3. Remove the PC card retaining bracket by removing two screws as shown in figure 6-1 and rotating the bracket up and out of top side rail.
4. Refer to illustration located on top of power supply shield.
5. Disconnect any cables from top of board to be removed (if any).

NOTE

There are two types of RF cable connectors, push-on and screw-on. Do not pull on the screw-on type until the threaded sleeve is completely un-screwed.

6. Release PC board by pulling locks up
7. Release board to be removed from the connector by pulling up on board extractors.

BOARD REPLACEMENT

1. Make sure PC board locks are up before inserting board shield in guides.
2. Insert PC board shield edges in proper guides.
3. Make sure board extractors are down before attempting to seat the connector.
4. While keeping board properly aligned in guides, push board all the way down until connector is seated.
5. Lock board by pushing locks down
6. Re-install the PC card bracket by inserting tabs in the top side rail holes completely while holding bracket vertical and then rotating it down into place.

CAUTION

The tabs on the bracket will be damaged by bending if they are not fully inserted into holes in top rail prior to rotating bracket down. If there is any resistance encountered while rotating the bracket down, the tabs are not fully inserted

Assembly Removal And Replacement Procedures

Analog Power Supply Removal Only
REMOVE THIS SCREW *

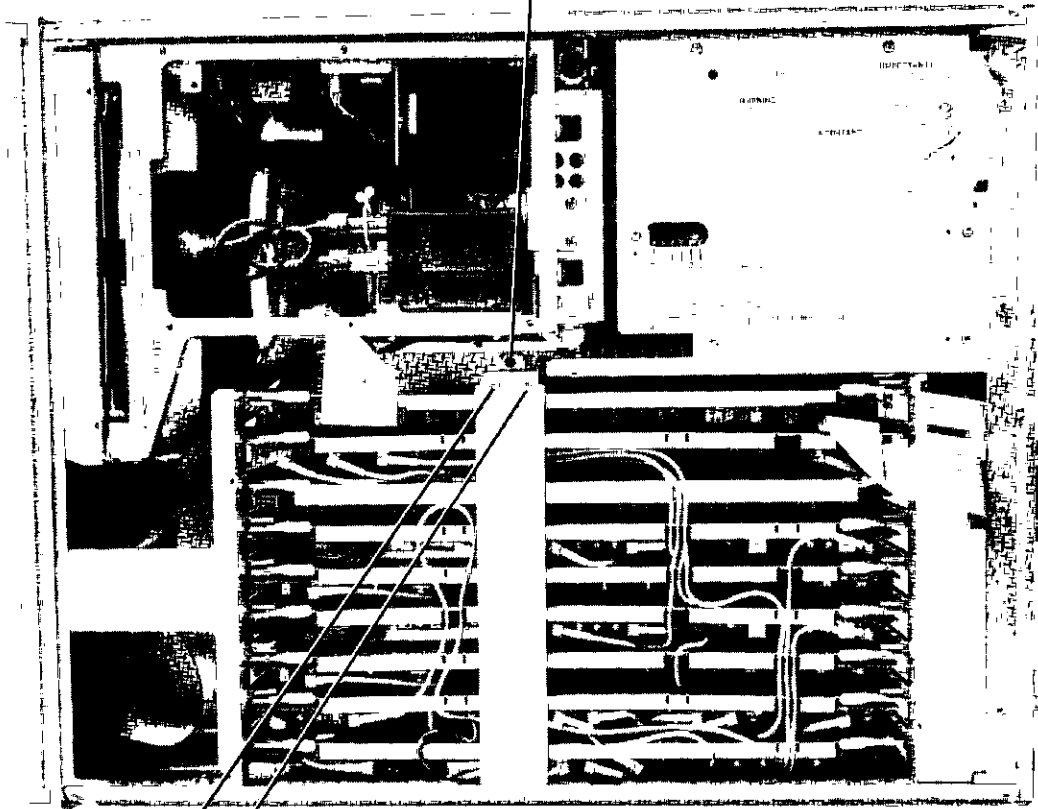

REMOVE THESE SCREWS *

* (Torx T-10, M3 x 8mm, HP Part No. 0515-0372)

Figure 6-1. PC Card Retaining Bracket Removal.

Assembly Removal And Replacement Procedures

6-5. AC POWER SUPPLY PC BOARD (A11)

BOARD REMOVAL

1. Disconnect power cable.
2. Remove top and left side covers.

WARNING

Hazardous voltages capable of causing injury or death are present when the power supply shields are removed and AC power is applied to the instrument. To avoid this hazard make sure the AC power cable is disconnected before continuing with this procedure.

3. Observe the red LED located on the AC Power Supply board (A11) through the top power shield. This LED indicates the presence of 300 volts and will stay illuminated until the filter capacitors discharge. Wait until this LED is no longer illuminated before proceeding to next step.
4. Remove top power supply shield.
5. Remove the screw that attaches ground wire (green/yellow) to top corner of rear frame.
6. Remove four screws from power supply side cover as shown in figure 6-2.
7. Remove two screws which attach power supply module to rear panel as shown in figure 6-3.
8. Slowly pull the AC Power Supply module (A11) rearward approximately 25 mm (1 in.) and disconnect the three cable connectors at the top front corner of the AC Power Supply board (A11).
9. Continue to pull power supply module rearward until the cable connector at rear of power supply board can be disconnected. Access to this connector is between module rear panel and instrument rear panel.
10. Once cable is disconnected in step 9, continue to pull module rearward until it clears the instrument.

BOARD REPLACEMENT

1. Reverse removal procedure to install module.

WARNING

Proper power supply grounding will be defeated if ground wire removed in step 5 above is not reconnected. To avoid a defeated ground, make sure this green/yellow wire is re-attached to top rear corner of the rear frame.

Assembly Removal And Replacement Procedures

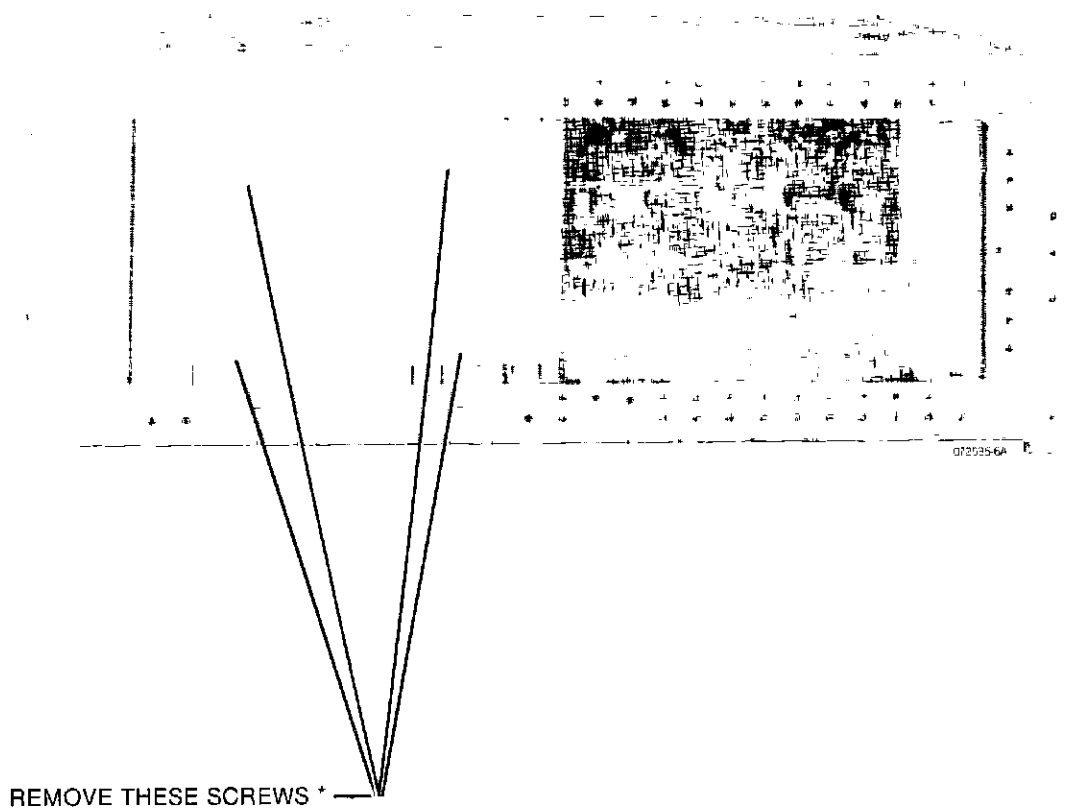

* (Torx T-10, M3 x 26mm, HP Part No. 0515-1024)

Figure 6-2. AC Power Supply Side Attaching Screws.

Assembly Removal And Replacement Procedures

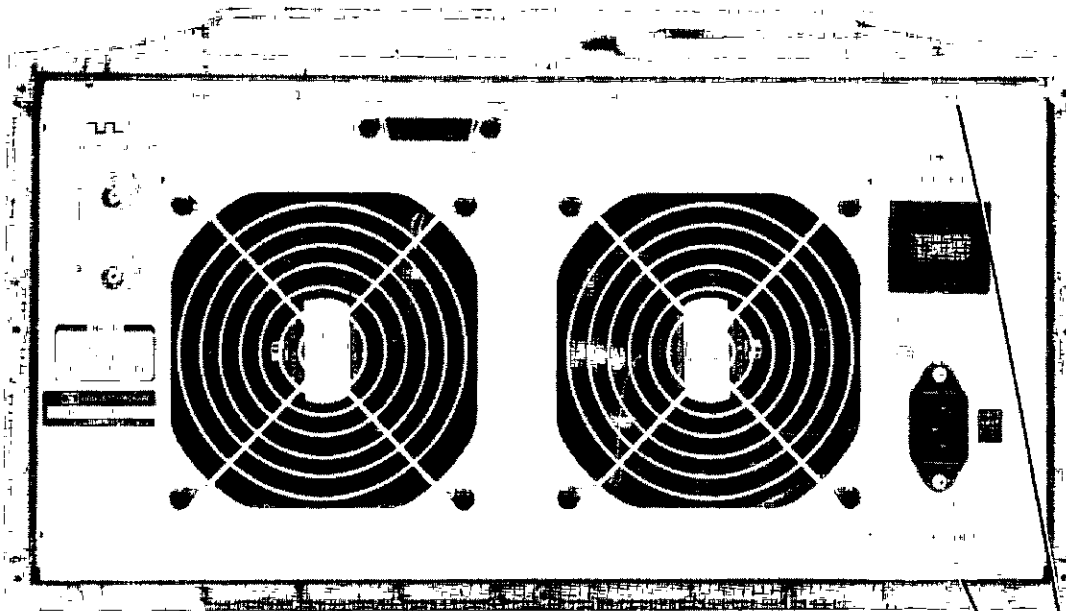

073585 1A

REMOVE THESE SCREWS *

* (Torx T-10, M3 x 8mm, HP Part No. 0515-0372)

Figure 6-3. AC Power Supply Rear Attaching Screws.

Assembly Removal And Replacement Procedures

6-6. ANALOG POWER SUPPLY PC BOARD (A12)

POWER SUPPLY BOARD REMOVAL

1. Disconnect power cable.
2. Remove top cover.

WARNING

Hazardous voltages capable of causing injury or death are present when the power supply shields are removed and AC power is applied to the instrument. To avoid this hazard make sure the AC power cable is disconnected before continuing with this procedure.

3. Observe the red LED located on the AC Power Supply board (A11) through the top power shield. This LED indicates the presence of 300 volts and will stay illuminated until the filter capacitors discharge. Wait until this LED is no longer illuminated before proceeding to next step.
4. Remove top power supply shield
5. Remove PC card retaining bracket (refer to paragraph 6-4, step 3).
6. Remove PC card retaining bracket support attaching screw as shown in figure 6-1.
7. Remove top four screws that attach fan housing to rear panel and loosen bottom four screws approximately four turns (see figure 6-14). This allows fan housing to tilt back at the top approximately 40 mm (1.6 in.) which provides necessary clearance for rotating power supply board in step 9.
8. Disconnect the Analog Power Supply board (A12) cable connector from the top front corner of the AC Power Supply board (A11).
9. Loosen Analog Power Supply board retaining screw as shown in figure 6-4.
10. Release power supply board connector by pulling board straight up and off of guide posts.
11. Remove Analog Power Supply board from instrument by lifting front edge of board first and rotating board up and out of instrument.

BOARD REPLACEMENT

1. Reverse removal procedure to install board

Assembly Removal And Replacement Procedures

6-7. DIGITAL POWER SUPPLY PC BOARD (A13)

POWER SUPPLY BOARD REMOVAL

1. Disconnect power cable.
2. Remove top cover.

WARNING

Hazardous voltages capable of causing injury or death are present when the power supply shields are removed and AC power is applied to the instrument. To avoid this hazard make sure the AC power cable is disconnected before continuing with this procedure.

3. Observe the red LED located on the AC Power Supply board (A11) through the top power shield. This LED indicates the presence of 300 volts and will stay illuminated until the filter capacitors discharge. Wait until this LED is no longer illuminated before proceeding to next step.
4. Remove top power supply shield.
5. Remove top four screws that attach fan housing to rear panel and loosen bottom four screws approximately four turns (see figure 6-14). This allows fan housing to tilt back at the top approximately 40 mm (1.6 in) which provides necessary clearance for rotating power supply board in step 9.
6. Disconnect the Digital Power Supply board (A13) cable connector from the top front corner of the AC Power Supply board (A11).
7. Loosen Digital Power Supply board retaining screw as shown in figure 6-4.
8. Release power supply board connector by pulling board straight up and off of guide posts.
9. Remove Digital Power Supply board from instrument by lifting front edge of board first and rotating board up and out of instrument.

BOARD REPLACEMENT

1. Reverse removal procedure to install board.

Assembly Removal And Replacement Procedures

LOOSEN THE APPROPRIATE SCREW(S) *

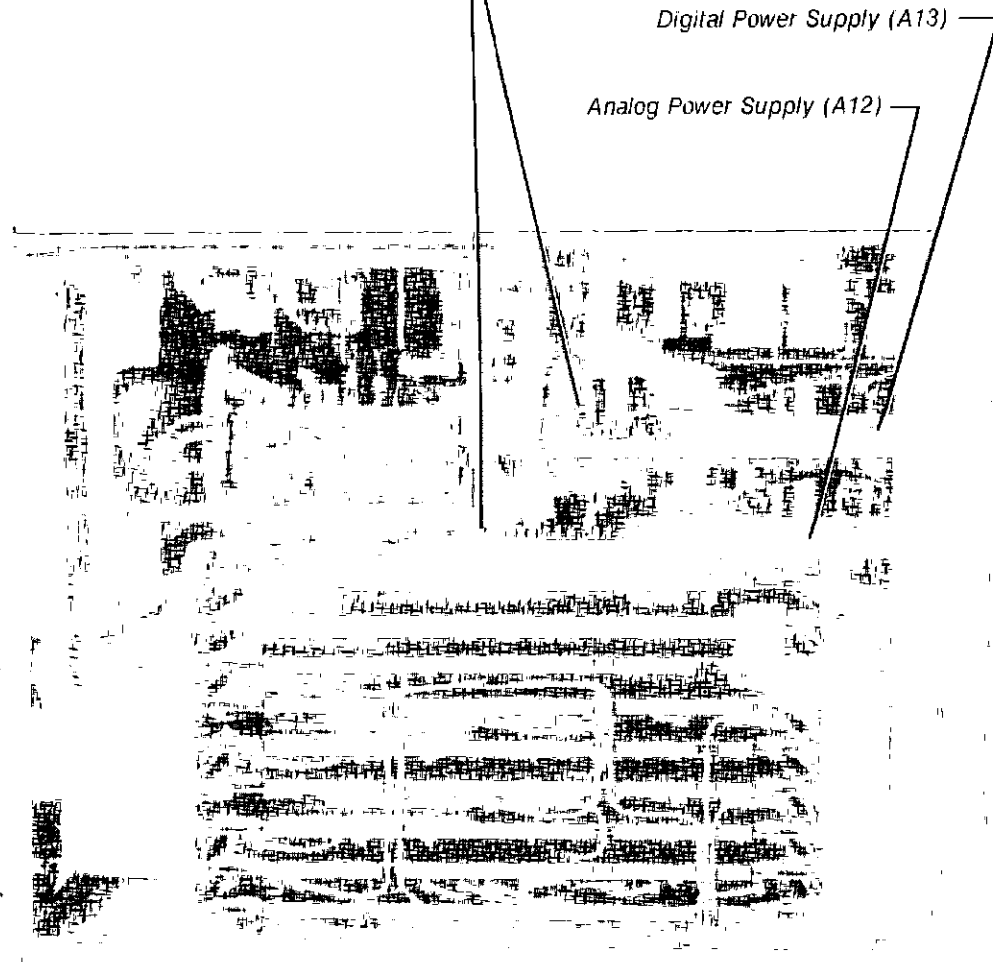

072585 3a

* (Captive screws, use flat blade screwdriver)

Figure 6-4. Analog/Digital Power Supply Retaining Screws.

Assembly Removal And Replacement Procedures

6-8. CRT BEZEL

BEZEL REMOVAL

1. While pushing down on top edge of bezel (see figure 6-5), pull top edge away from front panel until holding tabs are clear of the front panel.
2. Lift bezel slightly and pull bottom of bezel away from front panel
3. Pull bezel away from front panel just far enough to gain access to the ribbon cable connectors on Front Panel Control board (A15), which are located just to the right of the bezel opening in front panel.
4. While noting the location of the cable connector with the paint daub, disconnect the two ribbon cable connectors from the Front Panel Control board

NOTE

If the paint daub is not visible, the ribbon cables must be reconnected as follows: function keys cable (right side of bezel) to top connector on Front Panel Control board and menu keys cable (bottom of bezel) to bottom connector on Front Panel Control board

BEZEL REPLACEMENT

1. Reverse the removal procedure to install bezel.

Assembly Removal And Replacement Procedures

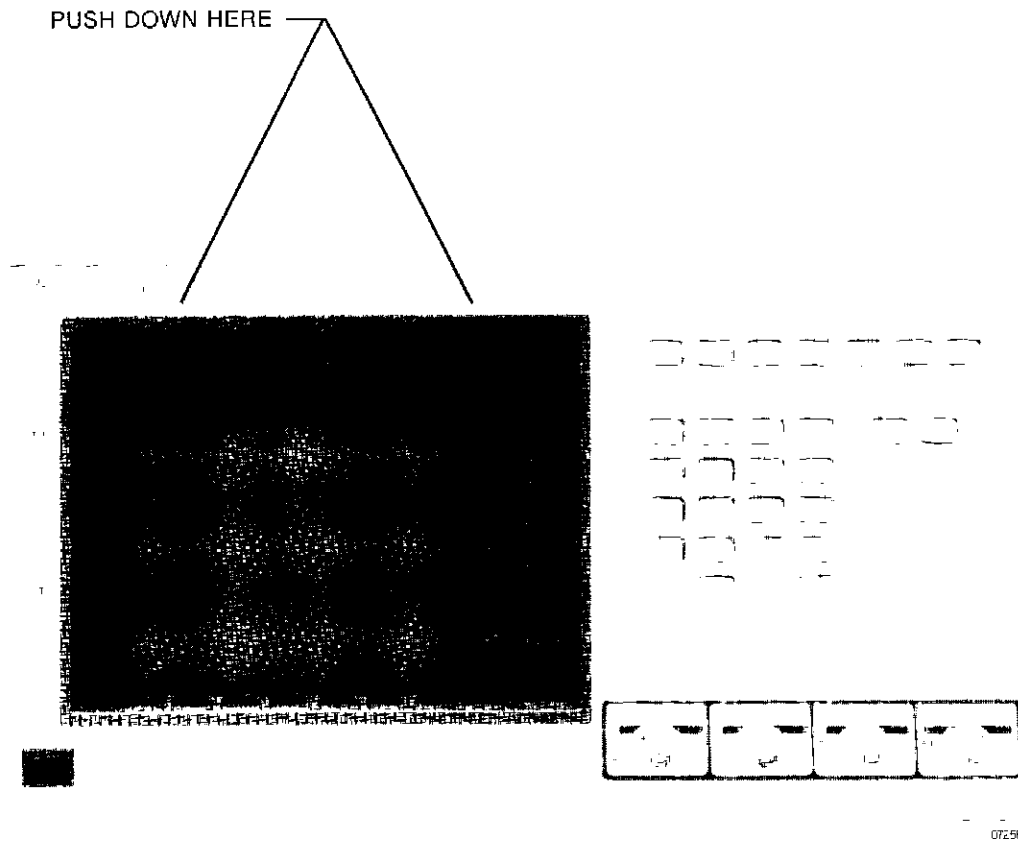

Figure 6-5. CRT Bezel Removal Pushing Locations.

Assembly Removal And Replacement Procedures

6-9. FRONT PANEL, FRONT PANEL CONTROL BOARD (A15), AND CRT CONTROL BOARD (A18)

NOTE

Use steps 1 through 9 to remove front panel, steps 1 through 10 to remove CRT Control board, or steps 1 through 9 and steps 11 and 12 to remove Front Panel Control board

FRONT PANEL REMOVAL

1. Disconnect power cable.
2. Remove rear feet.
3. Remove top, bottom and side covers.
4. Remove top, bottom and side trim strips by carefully prying up at the ends of the strips with a flat blade screwdriver.
5. Disconnect Front Panel Control board (A15) ribbon cable connector at I/O board (A1).
6. Remove the front panel screws as shown in figures 6-6, 6-7, 6-8 and 6-9.
7. Remove three front panel to deck attaching nuts as shown in figure 6-10.
8. Pull front panel just far enough to gain access to the cable connector on the CRT Control board (A18) and the in-line standby switch cable connector (left of bezel) and disconnect connectors.
9. Open the two cable ties just below the CRT opening and remove the cable from them. Remove cable clamp from bottom right side of CRT shield by squeezing and rotating clamp. The front panel can now be completely removed from front of instrument.

CRT CONTROL BOARD (A18) REMOVAL

10. Remove CRT Control board to front panel retaining screws.

Assembly Removal And Replacement Procedures

6-9. FRONT PANEL, FRONT PANEL CONTROL BOARD (A15), AND CRT CONTROL BOARD (A18) (Continued)

FRONT PANEL CONTROL BOARD (A15) REMOVAL

11. Disconnect the RPG (A20) to front panel board cable connector at the control board
12. Remove five control board to front panel attaching screws and remove board while passing RPG cable through hole in Front Panel Control board (A15)

FRONT PANEL, FRONT PANEL CONTROL BOARD AND CRT CONTROL BOARD REPLACEMENT

1. Reverse procedure to replace any of these assemblies.

NOTE

If pods were removed before the front panel was removed, install them and position the front panel so that the pod opening is centered around the pods before tightening any of the front panel hardware.

Assembly Removal And Replacement Procedures

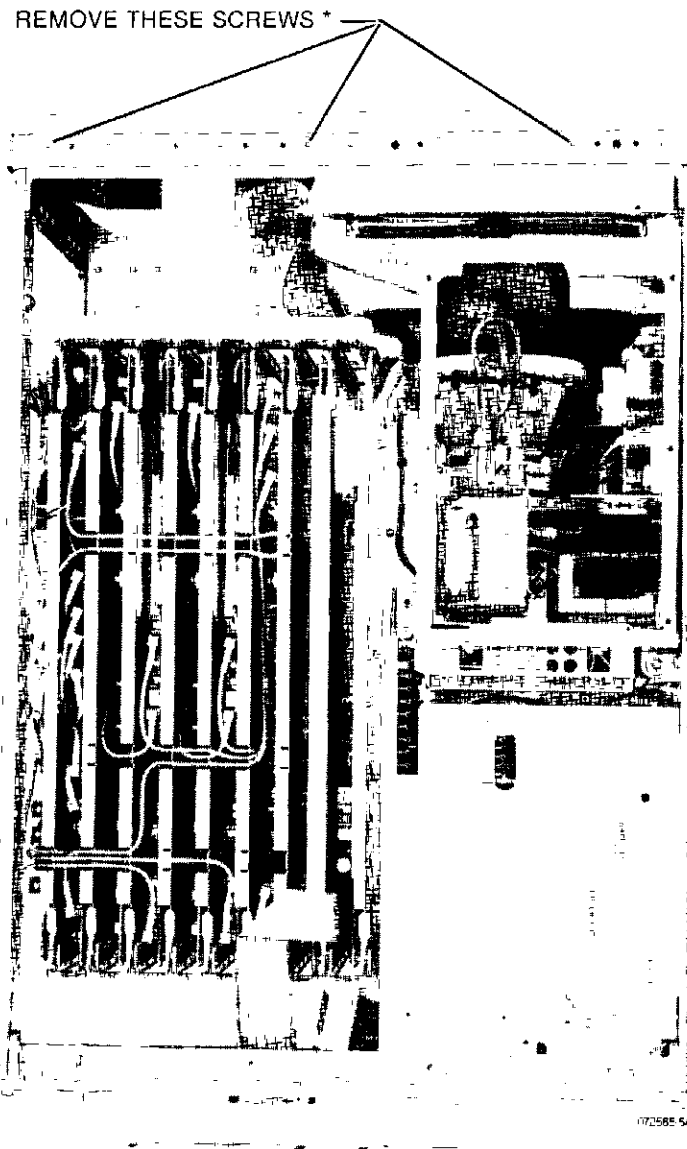

* (Torx T-15, M4 x 10mm, HP Part No. 0515-1104)

Figure 6-6. Top Front Panel Attaching Screws.

Assembly Removal And Replacement Procedures

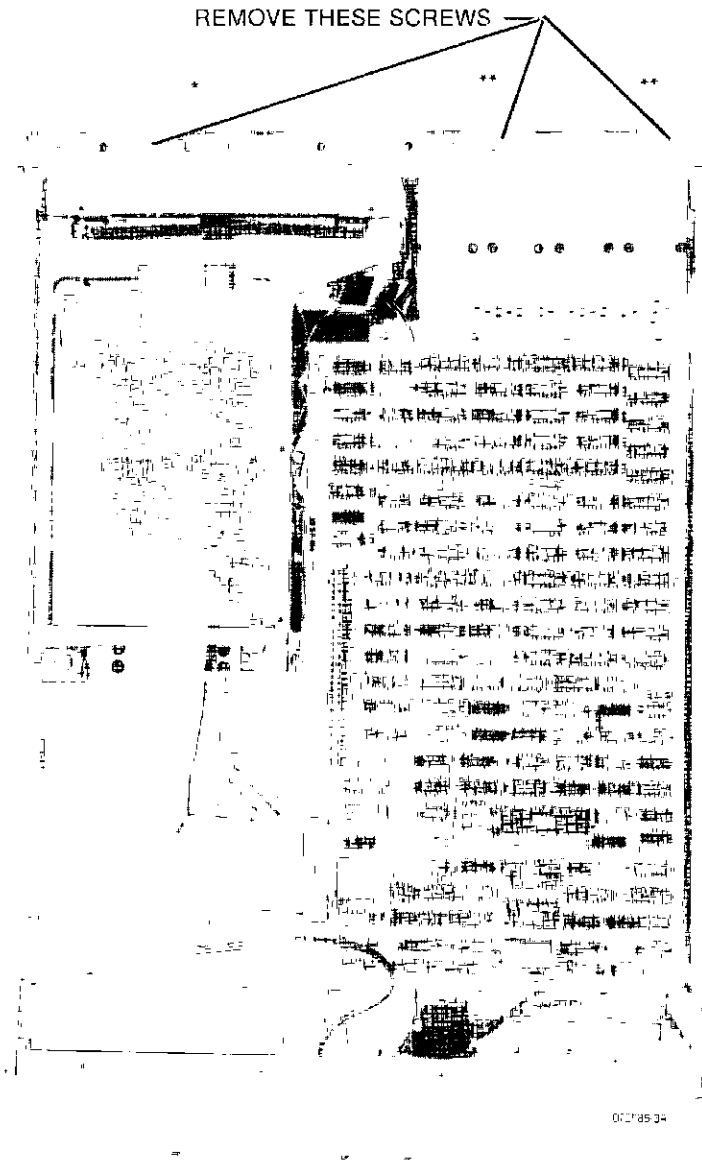

* (Torx T-15, M4 x 10mm, HP Part No. 0515-1104)

** (Torx T-15, M4 x 6mm, HP Part No. 0515-1228)

Figure 6-7. Bottom Front Panel Attaching Screws.

Assembly Removal And Replacement Procedures

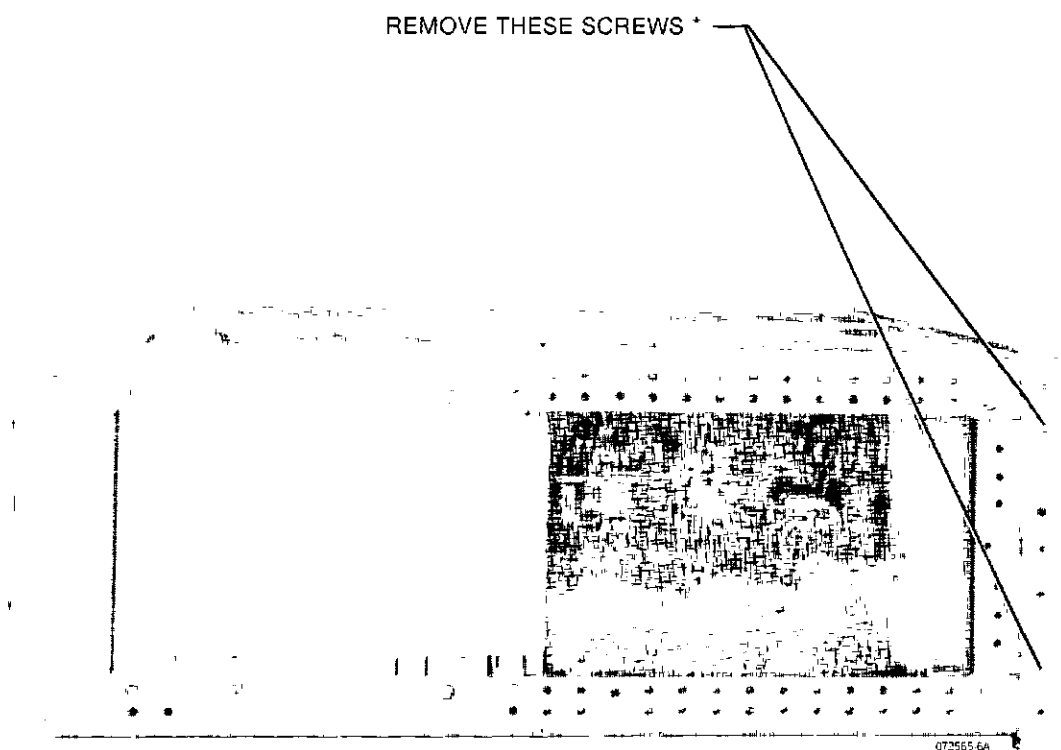

* (Torx T-15, M4 x 10mm (F.H.), HP Part No 0515-1104)

Figure 6-8. Left Side Front Panel Attaching Screws.

Assembly Removal And Replacement Procedures

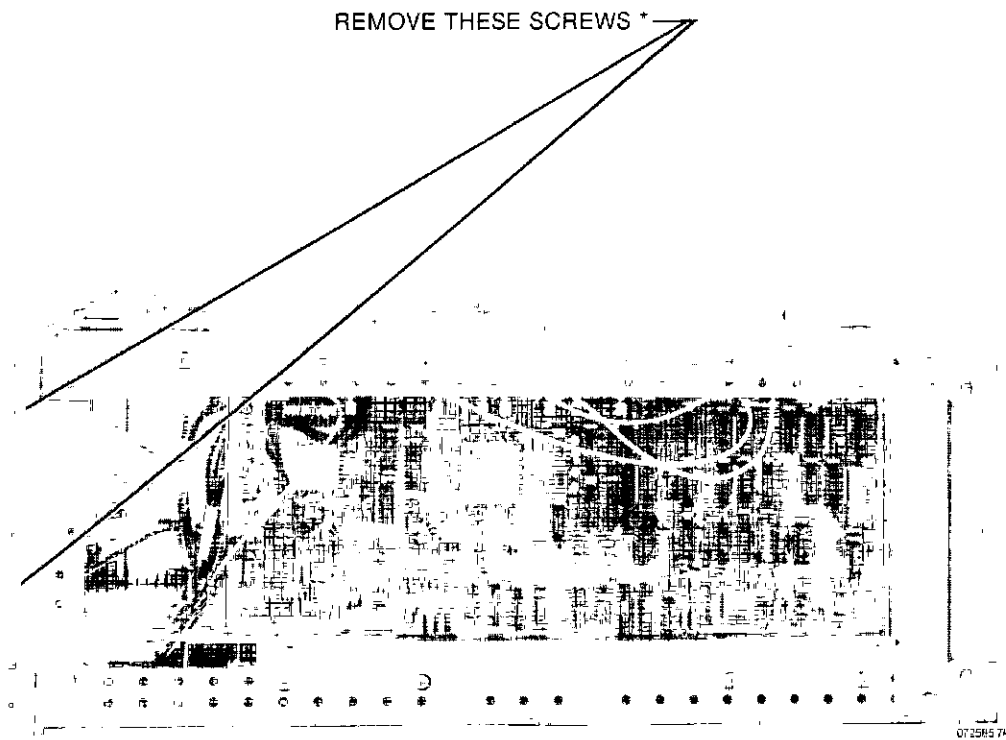

* (Torx T-15, M4 x 10mm (F.H), HP Part No. 0515-1104)

Figure 6-9 Right Side Front Panel Attaching Screws.

Assembly Removal And Replacement Procedures

NOTE

There are only two nuts visible in the figure. The third nut is behind the front panel frame side



* (M4 hex nut, HP Part No. 0535-0043)

Figure 6-10. Front Panel to Deck Attaching Nuts

Assembly Removal And Replacement Procedures

6-10. CRT DISPLAY MODULE (A19)

CRT MODULE REMOVAL

1. Remove Front Panel (refer to paragraph 6-8).
2. Disconnect flat ribbon cable (W12) from Display PC board and remove cable from clip.
3. Remove four module to front panel screws as shown in figure 6-11.
4. Remove two module to side frame screws as shown in figure 6-12.
5. Slowly pull CRT Display module forward until the module power cable (W8) can be disconnected at AC Power Supply board (A11).

NOTE

The module power, display board and control board cables will be used with the new module. Therefore, they will need to be disconnected from module when they are removed from instrument.

6. Continue pulling CRT Display module forward until it clears the instrument.

NOTE

While pulling module forward, make sure the module power cable connector does not catch on any part of the instrument.

7. Note the routing of the module power, Display board and CRT control board cables for proper installation in the new module and remove cables from module PC board.

CRT MODULE REPLACEMENT

1. Reverse removal procedure to install module.

NOTE

Do not tighten the screws removed in step 3 and 4 above, only start them and tighten just enough to hold module in instrument. These screws will be tightened in next step.

2. Align CRT with CRT bezel by pushing CRT Module forward on the left or right side as needed. While holding module in place, tighten module to front frame screws both top and bottom. Re-check CRT alignment, if alignment is correct, tighten the rear module attaching screws.

Assembly Removal And Replacement Procedures

REMOVE
THESE
SCREWS *

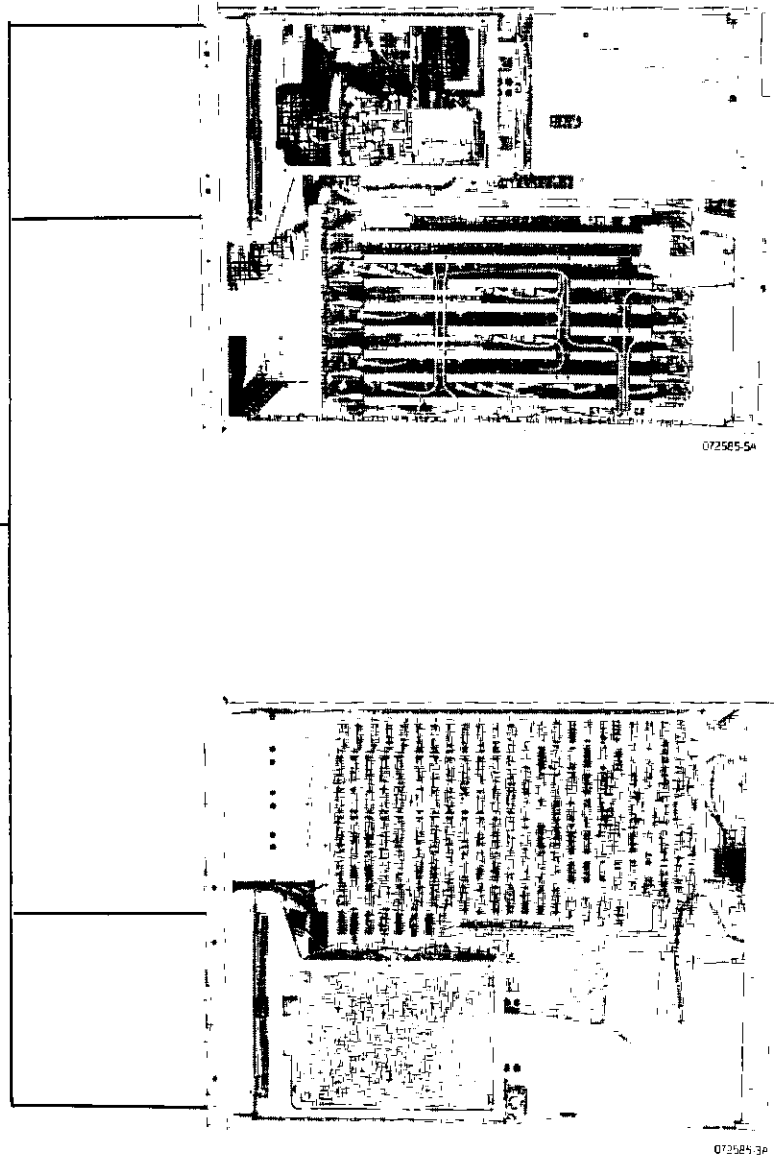

* (Torx T-15, M4 x 10mm, HP Part No. 0515-1104)

Figure 6-11. Front CRT Module Attaching Screws.

Assembly Removal And Replacement Procedures

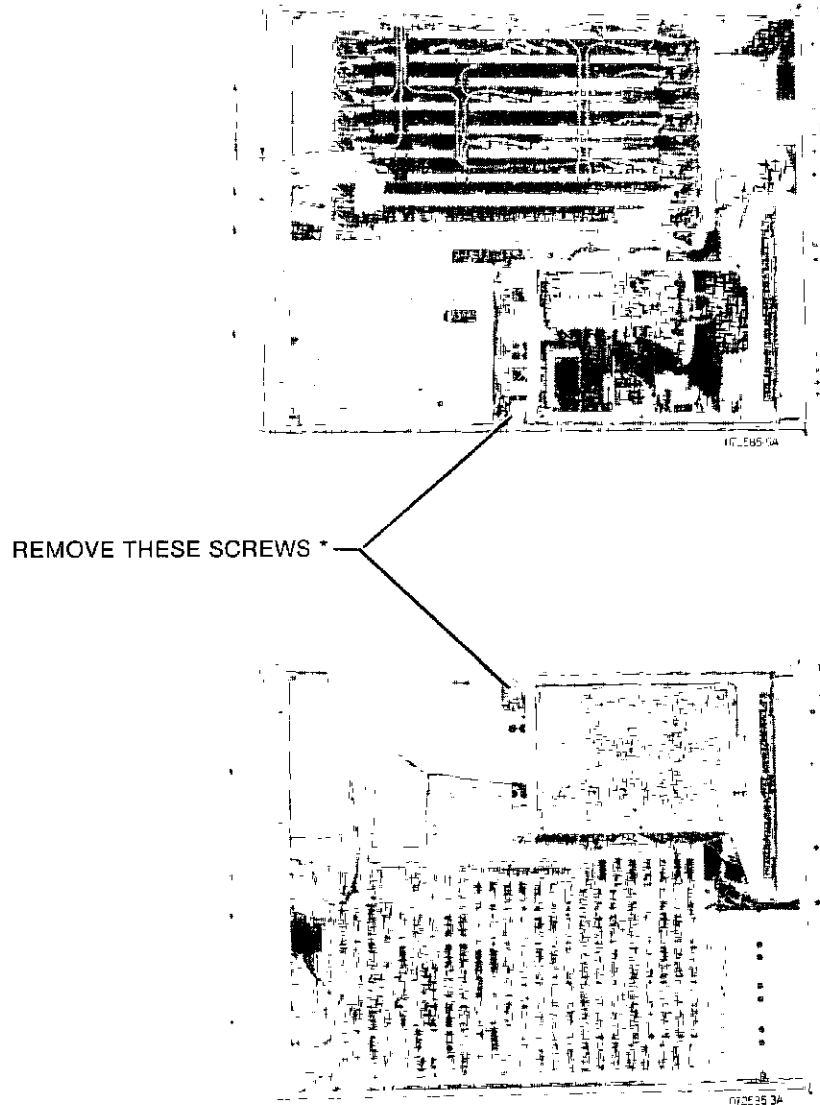

- * Screws - (Torx T-10, M3 x 12mm, HP Part No. 0515-0664)
- Metal washer - (HP Part No. 2190-0763)
- Rubber washer - (HP Part No. 3050-1238)

Figure 6-12. Rear CRT Module Attaching Screws

Assembly Removal And Replacement Procedures

6-11. POD CONNECTORS

POD CONNECTOR REMOVAL

1. Disconnect power cable
2. Remove pods.
3. Remove bottom cover.
4. Disconnect desired pod cable connector from its PC board.

NOTE

There are two types of RF cable connectors, push-on and screw-on. Do not pull on the screw-on type until the threaded sleeve is completely un-screwed.

5. Remove pod connector attaching screws (access to screws is through holes in front card cage bracket as shown in figure 6-13).
6. While noting pod cable routing, remove pod connector from card cage bracket.

POD CONNECTOR REPLACEMENT

1. Reverse removal procedure to install pod connectors.

Assembly Removal And Replacement Procedures

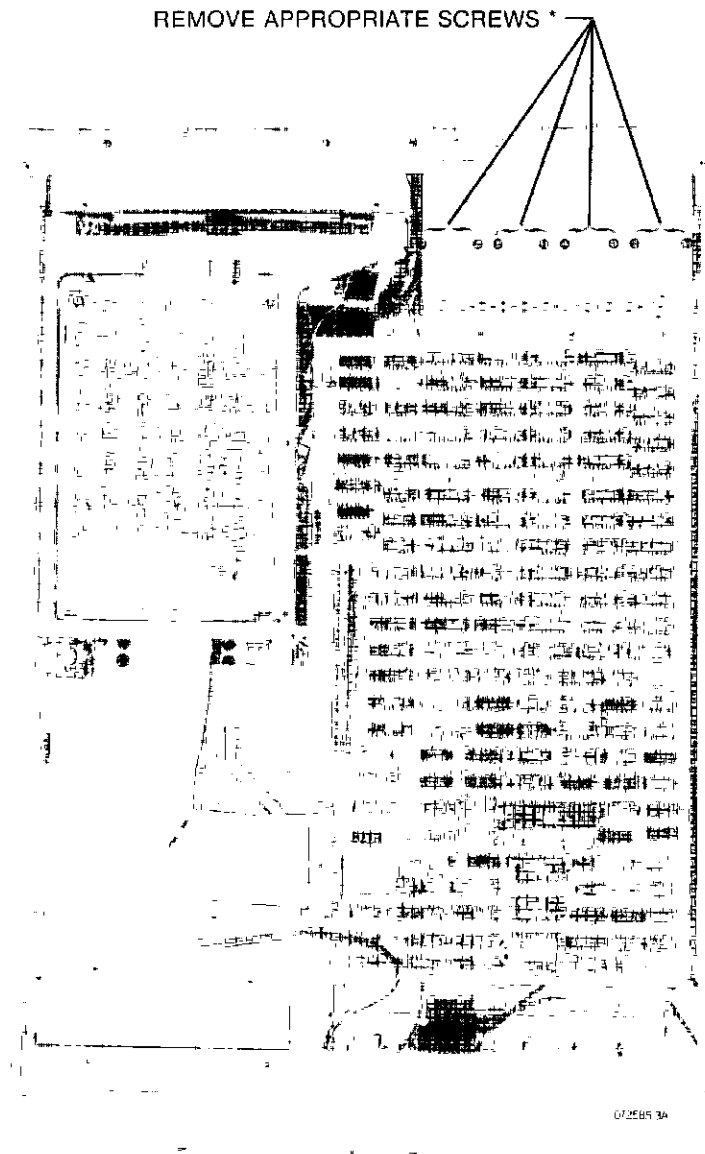

* (Torx T-10, M3 x 20mm, HP Part No 0515-1319)

Figure 6-13. Pod Connector Attaching Screws.

Assembly Removal And Replacement Procedures

6-12. FANS

FAN REMOVAL

1. Disconnect power cable.
2. Remove bottom cover.
3. Disconnect fan power cable from rear corner of Mother board (A14).
4. Remove fan housing attaching screws as shown in figure 6-14.
5. While noting fan cable routing, carefully remove fan housing from instrument.
6. Disconnect power cable connector from defective fan and remove fan from housing.

FAN REPLACEMENT

1. Reverse removal procedure to install fan

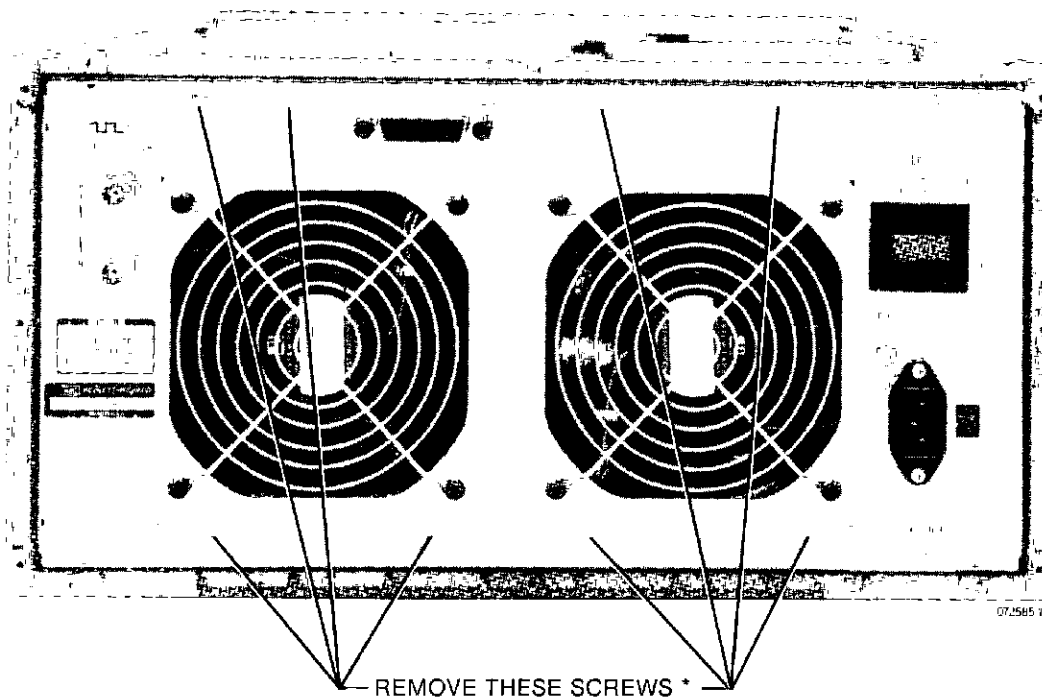

* (Torx T-10, M3 x 8mm, HP Part No. 0515-0372)

Figure 6-14. Fan Housing Attaching Screws.

Assembly Removal And Replacement Procedures

6-13. DISPLAY PC BOARD

BOARD REMOVAL

1. Disconnect power cable.
2. Remove bottom cover.
3. Disconnect ribbon cable (W12) from Display PC board (A10).
4. Remove Display PC board (A10) attaching screws as shown in figure 6-15.
5. Carefully lift board straight up to disengage Mother board connector.

NOTE

The Display board to Mother board connector will exhibit some removal resistance while the board is being removed. It is recommended the major lifting force be exerted on the edge of the Display board at the connector.

6. Note the "comb" type connector used between the Display and Mother boards. It consists of two separate combs held in place on the Display board by a connector guide and two screws. **This connector guide and the two comb connectors must be removed from the display board and installed on the new display board if it is being replaced. The connector DOES NOT come with the new display board.**

BOARD REPLACEMENT

1. Install the comb connectors and connector guide on Display board.
2. Reverse removal procedure to install board.

NOTE

Power for the Display board is obtained from the Mother board via the mounting screws. Therefore, the mounting screws must be installed and tightened before proper operation of the instrument can be expected

Assembly Removal And Replacement Procedures

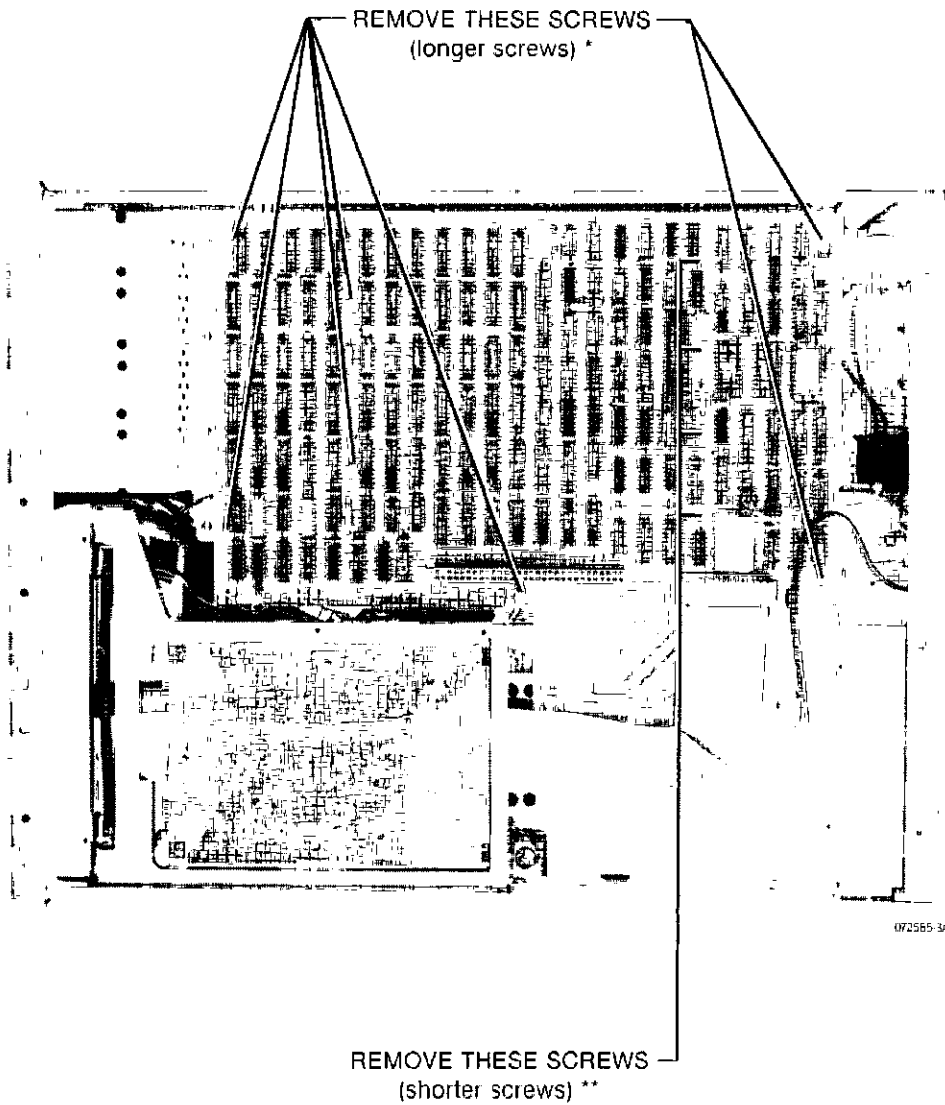

* (Torx T-10, M3 x 20mm, HP Part No. 0515-1410)

** (Torx T-10, M3 x 8mm, HP Part No. 0515-0372)

Figure 6-15. Display PC Board Attaching Screws.

Assembly Removal And Replacement Procedures

6-14. MOTHER BOARD (A14)

BOARD REMOVAL

1. Disconnect power cable.
2. Remove top cover
3. Remove all card cage PC boards (refer to paragraph 6-4).
4. Remove AC Power Supply (A11), Analog Power Supply (A12) and Digital Power Supply (A13) (refer to paragraphs 6-6, 6-7 and 6-8 respectively).
5. Remove Display PC board (A10) (refer to paragraph 6-13).
6. Disconnect fan power cable connector from corner of Mother board (A15)
7. Remove the two nylon cable clamps from bottom of Mother board (A15) by squeezing the clamp mount and pulling them from the holes in the board.
8. Remove the Mother board attaching screws and remove board (see figure 6-16).

BOARD REPLACEMENT

1. Reverse removal procedure to install board

NOTE

The Mother board and Display board share some of the same attaching screws. Therefore, when installing the Mother board (see figure 6-16), only install the screws removed in step 8 of the removal procedure at this time.

Assembly Removal And Replacement Procedures

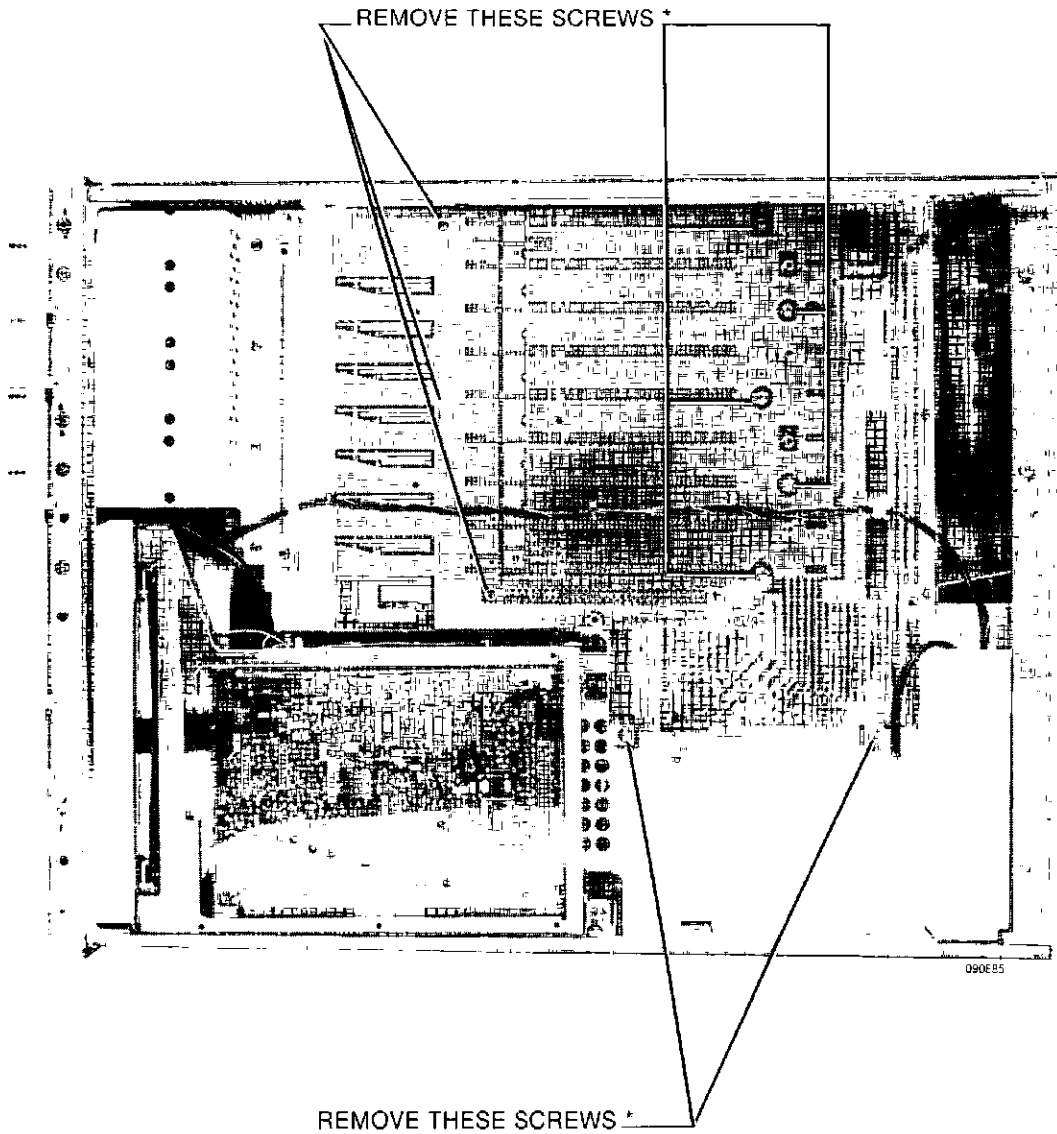

* (Torx T-10, M3 x 8mm, HP Part No. 0515-0372)

Figure 6-16. Mother Board Attaching Screws.



SECTION 6A

SERVICE MENUS/KEYS

6A-1 INTRODUCTION

This section describes the service menus and keys that are available to service personnel for calibration, troubleshooting and CRT display alignment. A basic understanding of these will be helpful in troubleshooting failures, however, Self-Test and Troubleshooting is covered specifically in Section 6B.

6A-2. SERVICE MENUS

The service menus can be accessed by pressing the *Utility* menu key which resides in the second level of the function menu. Once the Utility key is selected, five subkeys will be displayed: Cal Menu, Test Menu, CRT Setup, Color Cal Menu, and HPIB Menu.

CAL MENU. The Cal Menu allows you to calibrate the instrument and store the necessary calibration factors used. This menu is discussed in Section 6 of the Operating and Programming manual and will not be covered here.

TEST MENU. The Test Menu provides several keys that are used to setup and run internal diagnostics tests and view the results. These keys are discussed in the following paragraphs.

CRT SETUP. The CRT Setup Menu provides several keys that allow confidence testing and test patterns for setting up the CRT. These keys are discussed in the following paragraphs.

COLOR CAL MENU. The Color Cal Menu provides keys that are used to set the characteristics of the colors displayed. These characteristics include hue, saturation, and luminosity. This menu is discussed in detail in Section 6 of the Operating and Programming manual and will not be covered here.

HPIB MENU. The HPIB Menu provides keys that are used to set the HPIB attributes. These attributes are address number, Talk/Listen, and EOI. This menu is discussed in detail in Section 10 of the Operating and Programming manual and will not be covered here.

6A-3. TEST MENU

Five keys appear when the Test Menu is selected. These keys allow the user to access and run internal diagnostic tests and view the results. In addition, the position of each of the printed circuit boards located in the main card cage can be read and displayed.

6A-4. Repeat Loop / Run From Loop Key

The top key will toggle between **REPEAT LOOP** and **RUN FROM LOOP**. These keys in conjunction with the **Start Test** key will execute the internal self-test diagnostic routines. All input signals must be disconnected from the instrument for these tests.

NOTE

*When the instrument is left in a continuous **RUN FROM LOOP** mode for a period of time, an erroneous failure indication may occur. This is caused by random system noise and occurs less than 1% of the time. Since this is not a QA function it should be disregarded once you have verified it is not a true failure. A true failure only exists if the test is stopped and re-started and the same loop failure re-occurs at a rate greater than 1%.*

REPEAT LOOP. Selecting this mode will continuously execute the routine that has been entered using the entry devices (keypad, Knob, or increment/decrement) keys. Pressing **Start Test** will start execution and the loop will continuously run until the **Stop Test** key is pressed. Pressing **Display Errors** will show how many times the loop was executed and the number times the loop failed.

NOTE

*There are a number of loops that will blank or over-write the **Stop Test** key display on the CRT. However, the test can still be terminated by pressing the third function key from the top.*

RUN FROM LOOP. Selecting this mode will start execution from the loop entered and will proceed to execute all higher numbered loops. Upon reaching the last test, the cycle will be repeated.

NOTE

*If any test should fail, the instrument will change from **RUN FROM LOOP** to **REPEAT LOOP** and will repeatedly execute the loop that failed.*

6A-5. Interface Tests Key

When this key is chosen there are 17 internal instrument interface bus tests that may be selected by entering the test number with the entry devices. The tests are numbered 0 through 16. All input signals must be disconnected from the instrument for these tests.

NOTE

Tests 0 through 10, and 13 through 16 should be entered only by qualified service personnel. These are test loops for the purpose of creating a repetitive set of signals used for signature analysis troubleshooting (DSA). No useful information is gained from the CRT display when these troubleshooting loops are entered.

Test numbers 0-8 test the digital interface between the processor bus and the board loaded into the slot that corresponds to the test number. Test 9 tests the interface between the Display board and processor. The Display board is located on the bottom of the instrument rather than loaded in a slot. For example, if test 0 is selected the processor will attempt to read the identification code of the board loaded in slot 0. Slots 0 through 8 correspond to boards A1 through A9 respectively. Even though the codes are read, no information is displayed on the CRT.

To run interface tests 0 through 10, and 13 through 16, the test number is entered using the entry devices and the **Start Test** key is then pressed. To stop the test the **Stop Test** key is pressed. Tests 11 and 12 are entered in the same way but are terminated differently.

Test 10 checks the trigger level DAC of channel 3. Disconnect any signal inputs to this channel prior to running this test; otherwise, incorrect test results may occur.

Test 11 will display a keyboard mockup on the CRT. This test is used to verify that all front panel keys and RPG are working. After selecting Test 11 and pressing **Start Test**, press each front panel key. The displayed box corresponding to the key being pressed should light. The RPG control will move a cursor around the circle located in the lower right corner of the CRT. To exit this test the third key from the top must be pressed a second time. The first press will light the appropriate box and re-assign this key as **Stop Test**, the second press terminates the test.

Test 12 resets the system and initiates the power-up self-test. If the advisory message "Power-up Self-test Failed" should appear on the display, the failing loops may be found by pressing **Utility**, then **Test Menu**, then **Display Errors** keys.

Tests 13 and 14 are special DSA setups for testing ADC boards. Before initiating these tests the ADC to be tested must be installed in Slot 8 and the output of Sampler 1 must be connected to the ADC.

Test 15 checks the trigger level DAC of channel 4. Disconnect any signal inputs to this channel prior to running this test; otherwise, incorrect test results may occur.

Test 16 exercises a Display board failure LED and associated circuitry. This LED is described in more detail in section 6B.

Test 17, although not described earlier in this section, does exist. However, since it is based on a complex mathematical formula, it has no value in the field. It is used by the factory only.

6A-6. Start/Stop Test Key

This key is used to initiate any test where a test number is entered by one of the entry devices. Once the test number is entered, pressing **Start Test** initiates the test and the key toggles to **Stop Test**. Pressing **Stop Test** stops the test in progress and the key toggles back to **Start Test**.

NOTE

*There a number of tests that will blank or over-write the **Stop Test** key display on the CRT. However, the test can still be terminated by pressing the third function key from the top*

6A-7. Display Errors Key

Pressing this key will display the number of any loops which failed while running one of the following tests:

- Power-up self-test
- INTERFACE tests
- REPEAT and RUN FROM LOOP tests
- HP-IB commanded self-test

This display shows the current loop or last loop executed, the number of times the loop was executed, and the number of times that it failed. The bottom portion of the display shows all loops that failed starting with the first loop failure.

NOTE

There are four STATUS $\kappa = xxxxx$ lines in the Display Errors field that are for factory use only. There is no field usable information in this field of the display.

To return to the Test Menu, press **Exit Display Menu** key.

6A-8. Display Configuration Key

The 54110D motherboard has 9 slots and will accept any of the card cage PC boards at any location within the card cage, except the I/O board which must be loaded in slot 0. When the **Display Configuration** key is pressed the resulting display shows the location of each of the PC boards. The Processor board A2 will not be labeled on the display, but is normally loaded into Slot 1.

To return to the Test Menu, press **Exit Display Menu** key.

6A-9. CRT SETUP MENU

When CRT SETUP MENU is selected, four keys are displayed that allow access to CRT setup displays. The keys available are **Confidence Test**, **Pattern Off**, **Light Output Off**, and **Color Purity**.

6A-10. Confidence Test Key

When this key is selected, the confidence test pattern is displayed. In this display the CRT is divided into thirds vertically with a complete character set in the upper third, a group of seven color blocks in the center third, and a seven block grey-scale in the bottom third.

The top four lines of the character set display include the complete character set. The bottom line displays three sets of numerals. The first set of numerals are displayed in inverse video, the second set flashes between normal and inverse video and the third set is normal video and underlined.

In the center third of this display, seven color blocks are displayed. The colors from left to right are: beige, grey, red, yellow, green, amber, and cyan.

NOTE

Since color perception is subjective, any slight variation in colors from what is described here should be disregarded.

In the bottom third of the CRT a seven block grey-scale is displayed with black on the left and white on the right. This grey-scale display is used in the CRT Display Module adjustments when necessary.

6A-11. Pattern Off Key.

When the CRT SETUP MENU is selected, this key is initially **Pattern Off**. Selecting the **Pattern Off** once will display a white cross-hatch pattern over the entire CRT and the **Pattern Off** key changes to **Pattern White**. Inside the cross-hatch pattern there are groups of dots in the center and at the 12, 3, 6 and 9 o'clock positions. In addition to the dots, there are test matrices in the center and corners. This pattern is used in the CRT Display Module adjustments when necessary.

Pressing **Pattern White** key changes the pattern color to red and the key changes to **Pattern Red**. Successive selections of this key will change the color of the pattern to green and then blue.

When the blue pattern is being displayed, the key will be labeled **Pattern Blue**. Pressing the **Pattern Blue** key changes the display to a white cross-hatch pattern on the top half of the CRT and the bottom half is solid white. The key then changes to **HV Reg**. This test is used primarily by the factory, however, it will indicate the need for repair if there are severe high voltage problems.

Pressing the **HY Reg** key changes the display to a solid white screen with cross hatch lines. The key then changes to **I White**. Successive selections of this key changes the color to red, green and then blue. These color displays are used in the CRT Display Module adjustments when necessary.

Selecting **I Blue** key changes the display to a cross-hatch pattern with the inside flashing between solid white and cross-hatch. The key changes to **Bounce**. This test is primarily used by the factory, however, it will indicate the need for repair if there are severe high voltage problems.

Pressing **Bounce** key exits this set of tests and returns the CRT SETUP MENU.

6A-12. Light Output Key.

Selecting **Light Output** key causes the CRT to display a band of white across the horizontal length of the display in the center and approximately two-thirds of the total vertical height. Successive selections of this key will change the color of this band to red, green, blue and then a grey-scale. Each time the key is selected, it also changes to the appropriate description. These displays are used by the factory.

Selecting the **Grey-Scale** key exits this set of tests and returns the CRT SETUP MENU.

6A-13. Color Purity Key.

Selecting **Color Purity** key causes the CRT to display a full white raster. Successive selections of this key changes the color of the raster to red, green and then blue. Each time the key is selected, it also changes to the appropriate description. These displays will be used in the CRT Display Module adjustments when necessary.

Selecting the **Blue** key exits this set of tests and returns the CRT SETUP MENU.



SECTION 6B

SELF-TESTS/TROUBLESHOOTING

6B-1 INTRODUCTION

This section describes the Self-Tests and Troubleshooting routines that service personnel can use to locate failures to the PC board level. A basic understanding of the Service Menus and Keys will be helpful in troubleshooting failures and is covered specifically in Section 6A.

6B-2. FAILURE INDICATIONS

The 54110D will indicate failures in one of two ways; improper display (blank, distorted or random) on the CRT after power-up or "Powerup Self Test Failed!" displayed on the CRT.

NOTE

The "Powerup Self Test Failed!" advisory is only displayed for approximately 9 seconds and the CRT warmup time may exceed 9 seconds if the instrument has been turned off for any length of time. In these cases, the CRT will be slow in displaying anything and the instrument power should be cycled to STBY and back to ON after being on approximately 1 minute.

6B-3. FAILURE VERIFICATION

A true failure exists when the "Powerup Self Test Failed!" advisory occurs both on actual powerup and after performing Interface Test 12 or if there is no display on the CRT after powerup.

NOTE

In addition to the front panel power switch (STBY), there is a main breaker power switch located on the rear panel. Before troubleshooting a "no display" failure, make sure the rear panel switch has not been inadvertently turned off.

6B-4. TROUBLESHOOTING SEQUENCE

Once it has been determined a true failure exists, the troubleshooting sequence flow diagram in figure 6B-1 should be followed. The flow diagram provides a systematic method of choosing the most appropriate paragraph or paragraphs that contain the needed troubleshooting information.

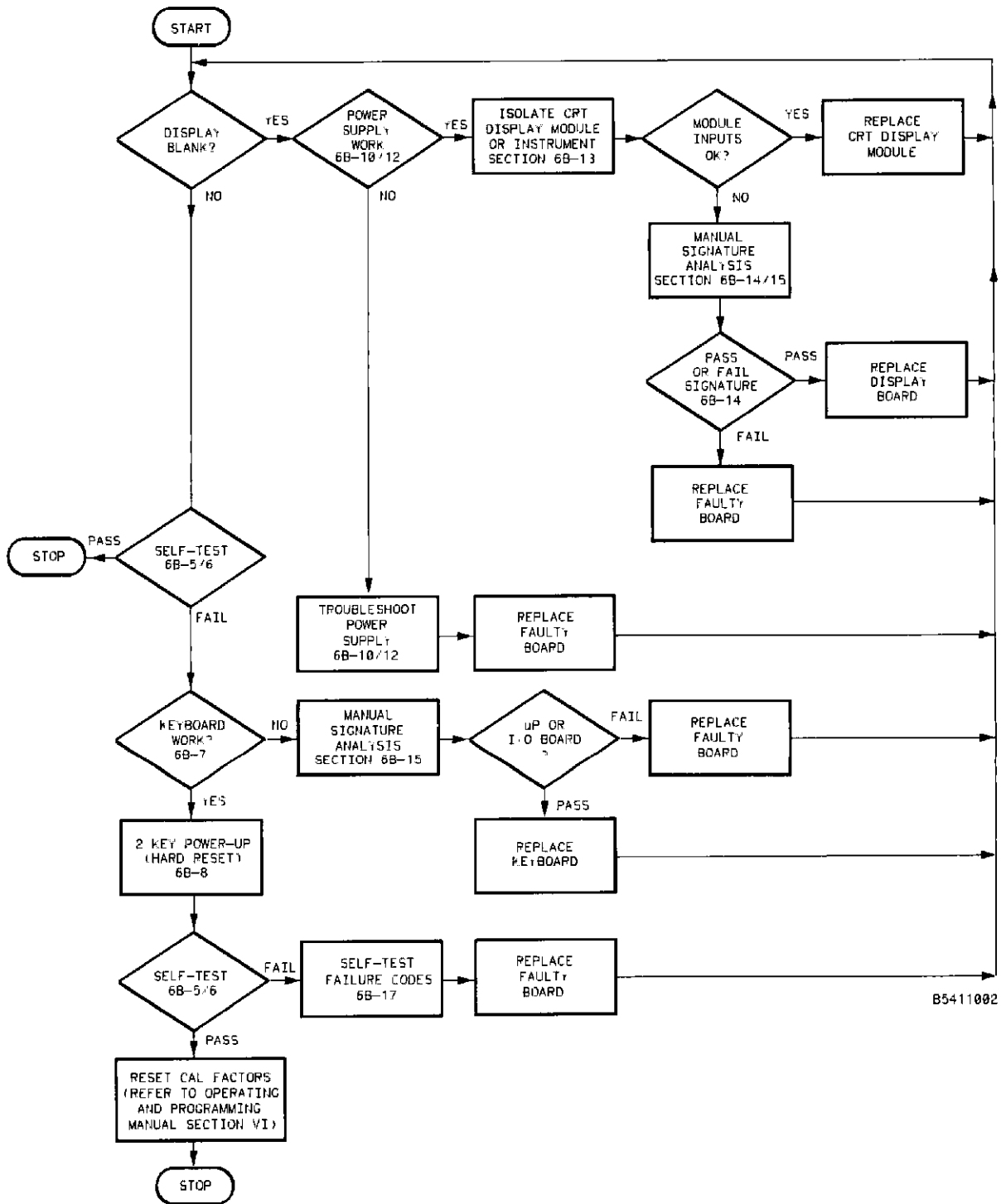

B5411002

Figure 6B-1. Troubleshooting Sequence Flow Chart.

6B-5. INTERNAL DIAGNOSTICS

The 54110D has routines resident in firmware that exercise many of the unit's circuits and checks them for proper functioning. All input signals must be disconnected from the instrument for these tests.

The processor upon command or automatically at power-up begins checking memory and then checks its ability to communicate via the internal bus. Once bus communication is established the processor will exercise and test circuits on other boards beginning with the digital boards.

Upon successful completion of the self-test, the advisory "Powerup Self Test Passed" appears approximately 4 seconds later. If however, a failure is detected, the advisory "Powerup Self Test Failed" appears. Some hardware failures will delay the appearance of the advisory as long as 30 seconds.

NOTE

Internal diagnostics only checks the instrument for proper functioning and not quantitative conformance to its published specifications. To check for conformance to specifications, refer to "Performance Tests" in Section 3 of this manual.

When a failure advisory appears and a true failure exists (see paragraph 6B-3), the troubleshooting process should be initiated (see paragraph 6B-4).

6B-6. PERFORMING SELF-TEST

In addition to the automatic execution of self-test at power-up, there are four additional ways to initiate self-test.

1. Pressing the internal reset switch located on the I/O board (A1).
2. Performing test 12 in the INTERFACE TESTS portion of the Test Menu.
3. Entering loop 0 in the RUN FROM LOOP portion of the Test Menu. This test will cause the instrument to repeatedly exercise the complete group of tests. If a failure occurs on any of the tests the instrument will change to REPEAT LOOP and will continue executing only the loop that has failed.

NOTE

*Initiating tests by pressing RUN FROM LOOP 0 or REPEAT LOOP does not clear the previous loop failures displayed using the **DISPLAY ERRORS** key. All other methods of generating self-test do clear the loop failures from DISPLAY ERRORS and then adds any failures that occurred during the current self-test.*

4. HP-IB command TEST (TST) will trigger a power-up self-test. If a failure occurs, error number -340 will be placed in the error queue. The error buffer may be read using the ERROR? command. Refer to Section 6 of the 54110D Operating and Programming Manual

6B-7. KEYBOARD (INTERFACE 11) TEST

This test is used to verify that all front panel keys and RPG are working. When INTERFACE TEST 11 is entered and initiated a keyboard mockup will be displayed on the CRT. The mockup consists of a box corresponding to each key on the front panel which will light when the key is pressed. The RPG mockup consists of a set of radial lines representing a circle in the lower right corner of the CRT. When the RPG is rotated, an O cursor will rotate around the circle.

To initiate the test, select **Utility** Menu, select **INTERFACE TESTS** key, enter 11 using the entry devices then press **Start Test**. To perform the test press each front panel key and verify each corresponding box lights; rotate the RPG and verify the O cursor rotates around the circle.

To exit this test the third key from the top must be pressed a second time. The first press will light the appropriate box and re-assigns this key as **Stop Test**, and the second press terminates the test.

6B-8. 2-KEY POWER-UP (HARD RESET)

There may be occasions when memory will have erroneous data written to it during power-up cycles that cause a false failure. Performing the 2-Key Power-up will ensure that memory is completely cleared so that the self-tests can be repeated without false failure indications. Whenever a "Powerup Self Test Failed!" or "Loop # = x" indication occurs more than once (true failure), a 2-Key Power-Up (Hard Reset) routine may clear the problem.

NOTE

*The software calibration factors are also erased from memory when a 2- Key Power-Up is performed. **Make sure the failure indication has occurred twice before using this procedure to avoid needlessly erasing the software calibration factors.** Once a 2-Key Power-Up routine is performed, the software calibration factors will need to be reset in memory (refer to Section 6 of the Operating and Programming Manual).*

To initiate the 2-Key Powerup (Hard Reset), turn the instrument to standby with the front panel power (STBY) switch. While holding the top and bottom function keys to the right of the CRT, turn on the instrument and hold the two function keys for the duration of the power up cycle (approximately 30 seconds maximum), or the CRT displays either a pass or fail advisory.

After the Hard Reset, repeat the specific self-test where the failure indication occurred. If the failure condition re-occurs, a true failure exists and troubleshooting will be necessary. Refer to "Troubleshooting Sequence" (paragraph 6B-4 and Figure 6B-1).

6B-9. TROUBLESHOOTING WITH NO DISPLAY

To troubleshoot the system when the display is not operating requires the failure causing no display to be found and corrected first. The recommended order of troubleshooting a "no display" problem is:

1. Locate and correct power supply failures (paragraph 6B-10).
2. Determine whether the CRT Module has failed and if so, replace it (paragraph 6B-13).
3. If the CRT Module is not at fault, perform Manual Signature Analysis (paragraph 6B-15).

Refer to the Troubleshooting Sequence Flow Diagram in figure 6B-1 for the sequence to follow while troubleshooting.

6B-10. TROUBLESHOOTING THE POWER SUPPLIES

The power supply consists of three PC board assemblies and when defective, one, two or all three must be replaced with an exchange assembly. The following procedure will isolate which board(s) has failed.

Since the power supplies are a current limiting-type, power supply failure indications can be caused by excessive loading somewhere else in the instrument. The first step when apparent power supply problems exist is to determine whether or not excessive loading is occurring.

6B-11. Power Supply Failure Indications

Power supply failures may or may not be easily apparent, therefore, a few simple checks can be made to verify power supply problems. With the top cover off, visual and voltmeter checks of the power supplies can be made. These checks can be made quickly by performing the following procedure.

1. Remove instrument top cover.
2. Visually inspect the +300 V LED on the AC Power Supply board (A11) by looking through the inspection hole in the top power supply shield (AC Power Supply is located closest to the left side rail). If the AC Power Supply has failed, this LED will NOT be illuminated.
3. Visually inspect the +120 V LED by looking rearward through the top rear of the CRT Display module chassis to the front edge of the AC Power Supply PC board (A11). This LED is located below the cable connectors on the front edge of the board. If the +120 V supply has failed, this LED will NOT be illuminated.

WARNING

Hazardous voltages capable of causing injury or death are present on the AC Power Supply board (A11) when power is applied regardless of whether the LED is illuminated or not. To avoid this hazard, DO NOT make any measurements on the AC Power Supply; and, if the board is to be removed due to failure, wait 3 minutes or more after power is disconnected to remove top power supply shield and handle the board. The waiting period is necessary to allow the filter capacitors to discharge.

4. Visually inspect the LEDs on both the Analog Power Supply (A12) and Digital Power Supply (A13) through the inspection holes in the top power supply shield. If the +18 V on the Analog Supply or the +5 V on the Digital Supply fails, the respective LED will NOT be illuminated.

NOTE

The LEDs on both the Analog or Digital Power Supply boards are a coarse indication of power supply failure since only one supply voltage on each board is monitored. A complete check of all voltage outputs on these boards must be made with a voltmeter to ensure proper operation of the power supplies.

6B-12. Excessive Loading Of Power Supplies

To rule out excessive loading of the power supplies as a cause of failure, each PC board must be removed from the power bus (refer to the assembly removal procedures in Section 6 of this manual). Start by removing the card cage boards one at a time and then the Display board (A10) until either all the boards are removed or the power supplies start to operate correctly.

NOTE

Since the Display board (A10) is only connected to the Digital Power Supply bus, DO NOT remove it for excessive loading when the Analog Power Supply is the only supply indicating a failure.

In addition to the analog and digital power supplies, there is a +120 V power supply for the CRT Display module located on the AC Power Supply board (A11). To check the +120 V supply for loading, disconnect the CRT Display module power cable and re-check the +120 V LED.

6B-13. CRT DISPLAY MODULE FAILURE ISOLATION

A "no display" failure must be corrected before troubleshooting the rest of the system. The most efficient method of troubleshooting a display failure is to first isolate the failure to either the CRT Display Module or the rest of the instrument. If the CRT Display Module is found to be defective, it should be replaced before continuing.

In addition to "no display" failures, incorrect display problems can also be isolated using this procedure in conjunction with "Display Board Failure Verification" paragraph 6B-14.

To isolate the problem, the following procedure causes the processor to write a known pattern of video to the module. The video waveforms, the vertical and horizontal sync signals, and the +120V primary module power are checked at the module inputs. If the inputs are present and correct, the module has failed.

Procedure:

1. Turn instrument to STBY using the front panel power switch.
2. Remove top and bottom covers.
3. Turn power on and check the +120 V module power at the module power input connector (see figure 6B-2). The correct voltage will be between +118 and +122 volts. If the +120 V supply voltage is absent at the connector, refer to "Excessive Loading Of Power Supplies" (paragraph 6B-12).
4. Set the monitor oscilloscope controls as follows:

Channel A&B	- Coupling	- dc
	- VOLTS/DIV	- 0.2 V/div
	- Mode	- alternate (ALT)
	- Trigger Source	- Chan A
Timebase	- Sweep	- Main
	- SEC/DIV	- 0.02 ms/div
Trigger	- Source	- internal
	- Slope	- negative

5. Using 10:1 divider probes, connect channel A of the monitor oscilloscope to vertical sync test point (V Sync TP) and channel B of the monitor oscilloscope to horizontal sync test point (H Sync TP). These test points are located on the Display board (A10). The vertical and horizontal sync signals are TTL levels and should resemble the waveforms in figures 6B-3 and 6B-4.

6B-13. CRT DISPLAY MODULE FAILURE ISOLATION (Continued)

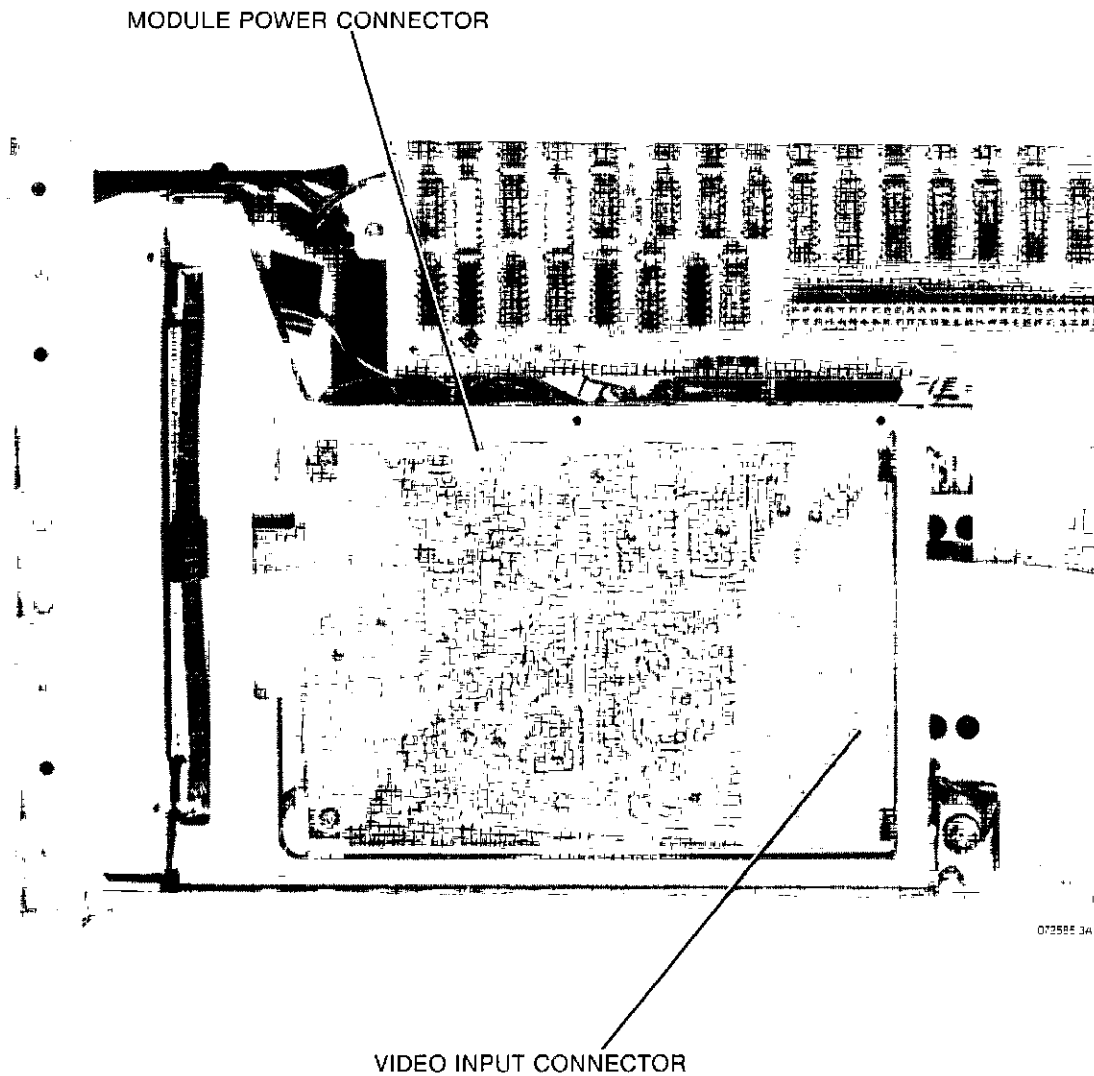

Figure 6B-2. CRT Display Module Input Connectors

6B-13. CRT DISPLAY MODULE FAILURE ISOLATION (Continued)

NOTE

Vertical sync period is 1667 ms

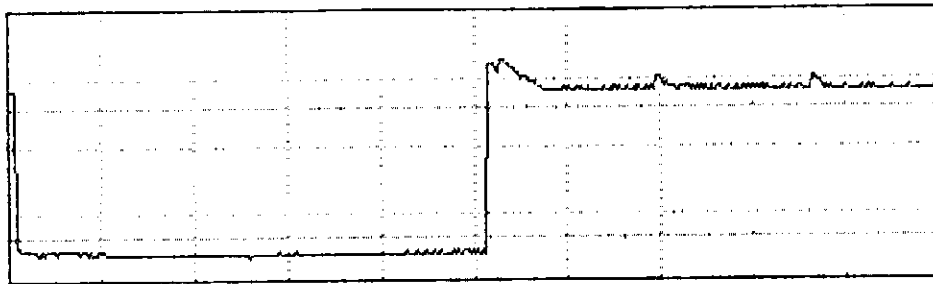

Figure 6B-3 **Correct Vertical Sync Waveform.**

NOTE

Horizontal sync period is 40 μ s.

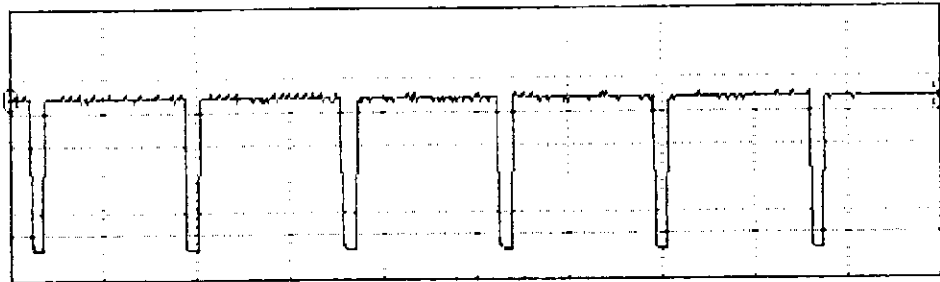

Figure 6B-4. **Correct Horizontal Sync Waveform**

6B-13. CRT DISPLAY MODULE FAILURE ISOLATION (Continued)

7. Change the monitor oscilloscope controls as follows:

Channel A - VOLTS/DIV - 0.02 V/div

Timebase - SEC/DIV - 5 μ s/div

8. Move clear plastic board shield on bottom of CRT Display module by pushing rearward until it clears front frame and hinge it away from the board.
9. While pressing the **VOLTS/SEC** and **PSEC** keys, turn instrument power on. Continue holding these keys for 30 seconds to ensure the processor power-up cycle is completed.
10. Using the channel B probe, check the red, green, and blue video signals at the module video input connector at pins 21, 29, and 37 respectively (see figure 6B-2). If these signals are correct, they will resemble those in figure 6B-5 through 6B-7. **However, they will vary slightly depending on the particular frame the oscilloscope triggers on.**

NOTE

Video signals can be adversely loaded down by input circuit failures within the CRT Display Module. Therefore, before assuming Display board failures, repeat this test with the video cable disconnected from the CRT Display Module and the measurements taken at the test points (R,G,B) on the Display board.

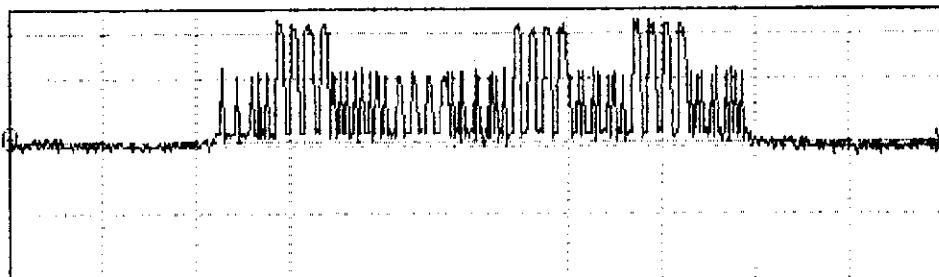

Figure 6B-5. **Correct Red Video Waveform.**

6B-13. CRT DISPLAY MODULE FAILURE ISOLATION (Continued)

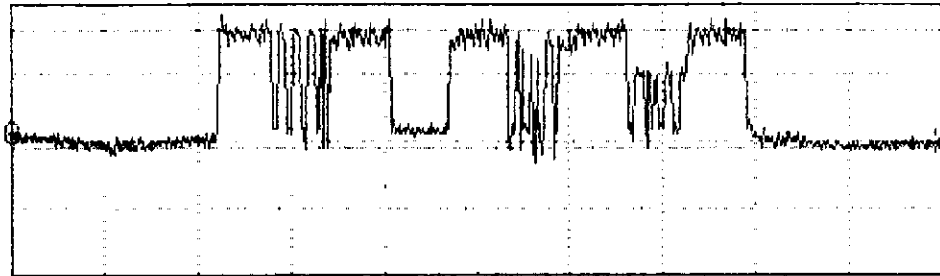

Figure 6B-6. Correct Green Video Waveforms

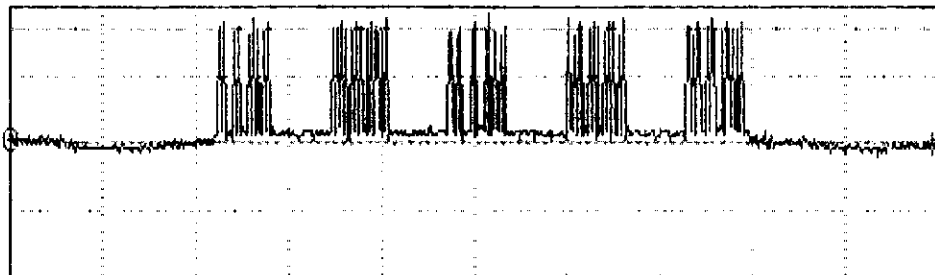

Figure 6B-7. Correct Blue Video Waveforms.

6B-14. DISPLAY BOARD FAILURE VERIFICATION

Once the CRT Display Module has been ruled out as the cause of a "no display" failure, the Display Board is then checked by performing the following procedure. This procedure assumes the inputs to the CRT Display Module have been checked and found to be in error.

The following procedure uses the instrument's internal diagnostics to attempt to write to and read from RAM on the Display board. If the processor is unsuccessful in doing the write/read routine, the Display board failure LED should be illuminated.

Procedure:

1. Cycle the 54110D front panel power switch to STBY and then to ON.
2. Observe the Display Board failure LED located on the outer edge, approximately half-way back from the front of the board. If the LED is on, a failure has been detected in the diagnostic routine. Do not replace the Display Board at this time. If the LED is *not* illuminated, proceed to step 4.
3. Proceed to Manual Signature Analysis (paragraph 6B-15) to verify the LED indication. If any of the signatures corresponding to loops 5 through 9 in table 6B-1 are read, the LED indication is verified and replacing the Display Board is recommended.
4. If the LED is not illuminated, turn power off and while holding the **VOLT/SEC** and **PSEC** keys, turn power on (hold these keys for 30 seconds). This two-key power-up will attempt to illuminate the LED. If the LED fails to light, one of three things has happened; the LED hardware failed, Display Board was not addressable, or the instrument software code failed before the Display Board is accessed.

NOTE

If the LED is illuminated by this test, the write/read routine has been successful and it indicates that the RAM portion of the Display board is functioning properly. However, there may be a failure on the Display board in that portion that cannot be checked by the internal diagnostics. At this point, step 5 of "Manual Signature Analysis (DSA)" (paragraph 6B-15) should be performed.

5. If the internal diagnostics passed signature is read while performing step 5 of "Manual Signature Analysis (DSA)" (paragraph 6B-15), failure verification requires substitution of the Display board.

In addition to a "no display" failure, a display board failure can also cause an incorrect display. In this case, there will be something displayed on the CRT and "Troubleshooting With The Display Operating" (paragraph 6B-16) should be referred to. If this proves to be inconclusive, Display board substitution is recommended.

6B-15. MANUAL SIGNATURE ANALYSIS (DSA)

The following procedure is provided in order to take signatures when the display or keyboard is not operating. Instead of looking up the loop numbers (display operating), the loop signature is used to find the probable cause of the failure.

The processor, when properly strapped, will execute the power-up self-test routine. When an error is found the processor will repeatedly execute the loop that is failing. By reading the signature at TP+5 on the processor and referring to the signature tables, the failing loop and board can be determined. **The I/O Board must be in slot 0 and the RF cabling must be correct before performing this procedure.**

Procedure:

1. Remove power from the instrument and connect a jumper from A2TP2 to A2TP3 on the processor board
2. Set the 5005B Signature Multimeter Mode to NORM and connect as follows:

START	A2TP1	Low to High	TTL
STOP	A2TP1	High to Low	TTL
CLOCK	A2TP6	Low to High	TTL
PROBE	A2TP+5	+5 Volts	TTL

3. Apply power to the 54110D and the 5005B Signature Analyzer.
4. After several seconds the 5005B readout will stabilize. Look-up the signature in Table 6B-1 to determine which board is causing the failure. **If none of the fail signatures appear, it would be assumed the instrument's diagnostics passed. In this case proceed to step 5 to verify this indication.**
5. Set the 5005B Signature Multimeter Mode to QUAL and re-connect as follows:

START	A2TP18	Low to High	TTL
STOP	A2TP18	High to Low	TTL
CLOCK	A2TP6	Low to High	TTL
QUAL	A2TP1	High	TTL
PROBE	A2TP+5	+5 Volts	

NOTE

Making these connections requires lifting the microprocessor board (A2) from the Mother Board approximately 2 to 3 inches to access the test points, and carefully re-installing board after the connections are made.

If the internal diagnostics did in fact pass, the signature will be 9F3P.

Table 6B-1. Signatures for Loop failures

LOOP NUMBER	SIGNATURE	PROBABLE CAUSE	LOOP NUMBER	SIGNATURE	PROBABLE CAUSE
0	6P1C	A2 PROCESSOR	31	PA20	A4 SAMPLER 1
1	C70H	A2 PROCESSOR	32	20P6	A6 SAMPLER 2
2	86H2	A2 PROCESSOR	33	P66P	A6 SAMPLER 2
3	H2H8	A2 PROCESSOR	34	FHH2	A5 ADC 1
4	C637	A2 PROCESSOR	35	A8F4	A5 ADC 1 or A4 SAMP1
5	6PCP	A10 DISPLAY	36	F431	A5 ADC 1 or A4 SAMP1
6	AUH6	A10 DISPLAY	37	3102	A5 ADC 1 or A4 SAMP1
7	AHH7	A10 DISPLAY	38	F409	A7 ADC 2
8	H7FC	A10 DISPLAY	39	5C43	A7 ADC 2 or A6 SAMP2
9	8A59	A10 DISPLAY	40	4337	A7 ADC 2 or A6 SAMP2
10	9H6P	A10 DISPLAY	41	377A	A7 ADC 2 or A6 SAMP2
11	5H82	A1 IO	42		NO OP
12	H5H8	A1 IO	43	5PU7	A9 TRIG. QUALIFIER
13	5H82	A1 IO	44	U7HA	A9 TRIG. QUALIFIER
14	057F	A1 IO	45	HA2F	A9 TRIG. QUALIFIER
15	57FP	A4 SAMPLER 1	46	1664	A9 TRIG. QUALIFIER
16	FPAP	A4 SAMPLER 1	47	8PA1	A9 TRIG. QUALIFIER
17	5HA2	A3 TIMEBASE	48	A188	A9 TRIG. QUALIFIER
18	45H9	A3 TIMEBASE	49	8893	A9 TRIG. QUALIFIER
19	PFHF	A8 TRIGGER	50	9390	A9 TRIG. QUALIFIER
20	HF08	A9 TRIG. QUALIFIER	51	90CF	A9 TRIG. QUALIFIER
21	08U6	A8 TRIGGER	52	CF42	A9 TRIG. QUALIFIER
22	PHHH	A8 TRIGGER	53	4222	A9 TRIG. QUALIFIER
23	HH9A	A8 TRIGGER	54	22FC	A9 TRIG. QUALIFIER
24	9A02	A8 TRIGGER	55	4596	A9 TRIG. QUALIFIER
25	0582	A8 TRIGGER	56	FC02	A9 TRIG. QUALIFIER
26	4FU4	A3 TIMEBASE	57	0201	A9 TRIG. QUALIFIER
27	9P9H	A3 TIMEBASE	58	OPU5	A9 TRIG. QUALIFIER
28	9HUH	A3 TIMEBASE	59	U58U	A9 TRIG. QUALIFIER
29	CUC7	A3 TIMEBASE	60	F7F5	A9 TRIG. QUALIFIER
30	70PA	A4 SAMPLER 1			

NOTE

If none of these signatures appear, it would be assumed the instrument's diagnostics passed. In this case proceed to step 5 to verify this indication.

6B-16. TROUBLESHOOTING WITH THE DISPLAY OPERATING

When the display is operating, the results of the internal diagnostics will be displayed on the CRT by selecting **Utility** key, then selecting **Test Menu** key and then **Display Errors** key.

Refer to "Self-Test Failure Codes" paragraph 6B-17 for decoding these results.

6B-17. SELF-TEST FAILURE CODES

Self-test failure codes provide a means of identifying which board or boards have failed. The internal diagnostics perform self-test loops and upon recognition of a failing loop, will continue repeating the failing loop. The failing loop number can then be displayed by selecting **Utility** key, then selecting **Test Menu** key and then **Display Errors** key.

In addition to the loop number, a failing loop provides a unique signature that can be used if the CRT Display is inoperative and manual signature analysis is required. By referring to the "Signatures For Loop Failures" table (table 6B-1), the probable cause can be found.

If the failure occurs in loops 0 through 14 or 43 through 60, a very high probability exists that the board corresponding to that loop in table 6B-1 is at fault. Loops 15 through 41 test the analog portion of the instrument and each of these loops is highly dependent upon multiple areas of hardware.

NOTE

The first failure listed in table 6B-1 for loops 15 through 41 is the likely candidate for replacement, however, it is recommended that further testing be performed using the Analog Troubleshooting Procedures and comparing the waveforms at the end of this section.

6B-18. TROUBLESHOOTING THE ANALOG PORTION OF THE 54110D

There are several techniques that can be used when troubleshooting the analog sections of the instrument. CRT displayed loop failures, channel isolation, and waveform comparisons may be used singularly or in tandem to isolate faulty boards.

Signature analysis is NOT utilized when testing the analog boards. The CRT will supply the same information, as could be obtained using signature analysis, when in the Display Errors mode. **If the CRT is not working, then THIS failure should be repaired prior to continuing.**

Procedure:

1. Execute the power-up self-test by one of the following methods:
 - a. Apply power to the instrument and the self-test routines are executed automatically.
 - b. Pressing the internal reset switch located on the I/O board.
 - c. Performing test 12 in the INTERFACE TESTS portion of the Test Menu
 - d. HP-IB command TEST (TST) will trigger a power-up self-test. If a failure occurs error number -340 will be placed in the error queue. The error buffer may be read using the ERROR? command. Refer to Section 10 of the 54110D Operating and Programming Manual.
2. Display the loop failures by selecting **Utility** key, then selecting **Test Menu** key and then **Display Errors** key.
3. Refer to table 6B-1 to determine which board is most likely causing the error to occur.

NOTE

Each of the analog test loops (15-41) is dependent upon circuitry on several boards. If more than one loop failure is shown on the display, the boards should be replaced in the order of the failures.

Waveform comparison and channel to channel signal exchange should be performed to further isolate problems before replacing boards.

6B-19. Board Swap (A4/A6) or (A5/A7)

The Sampling Boards (A4/A6) and the ADC Boards (A5/A7) of channel 1 and channel 2 are identical. If a problem is suspected on one of these boards, moving the suspected board to the opposite channel will determine if the problem follows the board being moved.

6B-20. Signal Exchange (Chan 1 and 2)

The IFout signal from either Sampling Board can be fed to the ADC of the opposite channel. This technique is fast and effective if either channel can trigger on and display a signal.

Procedure:

1. Apply the two CAL signals to both input channels
2. Press **AUTO-SCALE** If neither channel displays a triggered waveform use the Loop failure tables or the waveform comparisons to troubleshoot.
3. Set the bad channel up as follows:

Mode	- Normal
Display	- On
VOLTS/DIV	- 100 mV/div
OFFSET	- -215 mV

4. Remove the IFIN cable (J1) from both of the ADC boards. Connect the cable from the bad channel to the ADC board of the opposite channel. Change the trigger source to the bad channel and set trigger level to -215 mv. If a stable triggered signal appears on the CRT, the Sampling board of the bad channel is working and the problem is with the ADC board.

If no signal appears, check that the Sampling board is receiving MCLK before replacing the board.

6B-21. Waveform Comparison

The clocks and signals that must go between boards are ported via 50 ohm coaxial cables. Using the adapter cables supplied in the Product Support Kit (P/N 54100-69002) these signals may be fed to an oscilloscope. The observed waveforms can then be compared to figures 6B-9 through 6B-12.

To duplicate the waveforms shown, apply the two CAL signals to the inputs of both vertical channels and press **AUTO-SCALE**. Check that the 54110D has configured itself as follows and if not change the settings.

Chan 1 & 2	- Mode	- Normal
	- Display	- On
	- VOLTS/DIV	- 100 mV/div
	- OFFSET	- -215 mV
Timebase	- SEC/DIV	- 50 ns/div
	- DELAY	- 0 s
	- Delay Ref at	- Center
	- Auto	
Trigger	- Mode	- Edge
	- Source	- channel 1
	- LEVEL	- -215 mV
	- Slope	- Pos
	- HOLDOFF Time	- 70 ns

Using a SMB to BNC adapter cable connect the signal to be tested to the input channel of the oscilloscope.

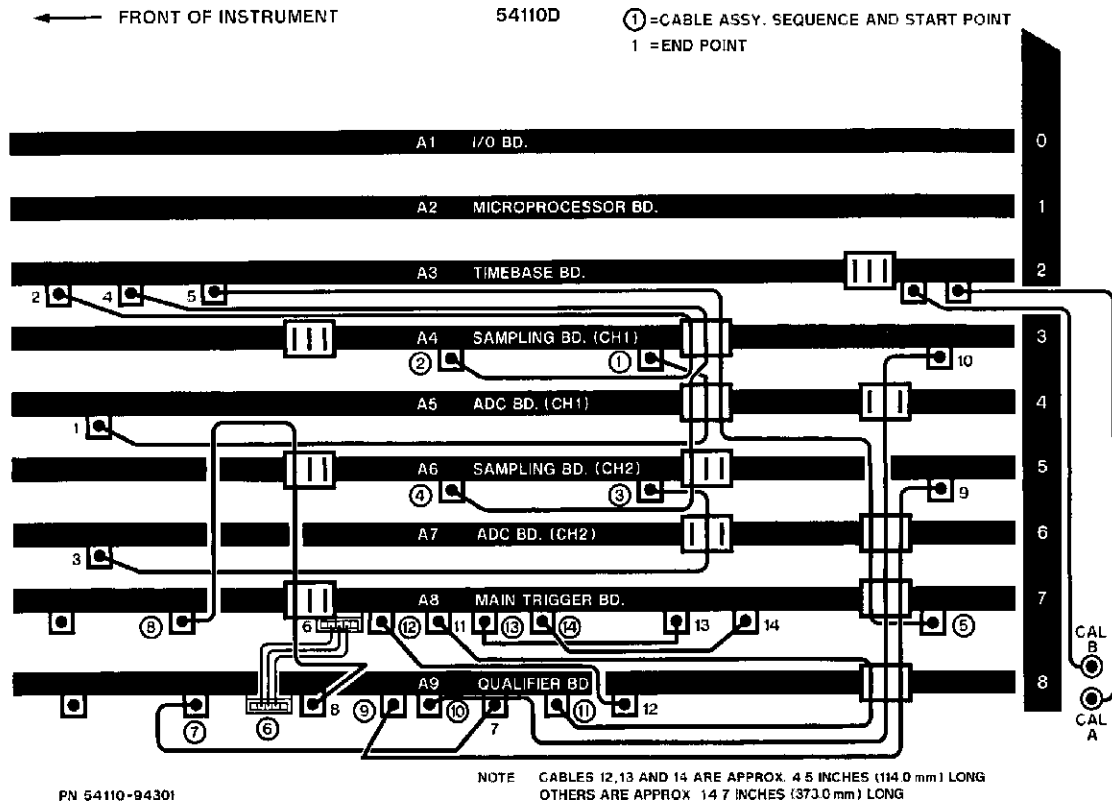
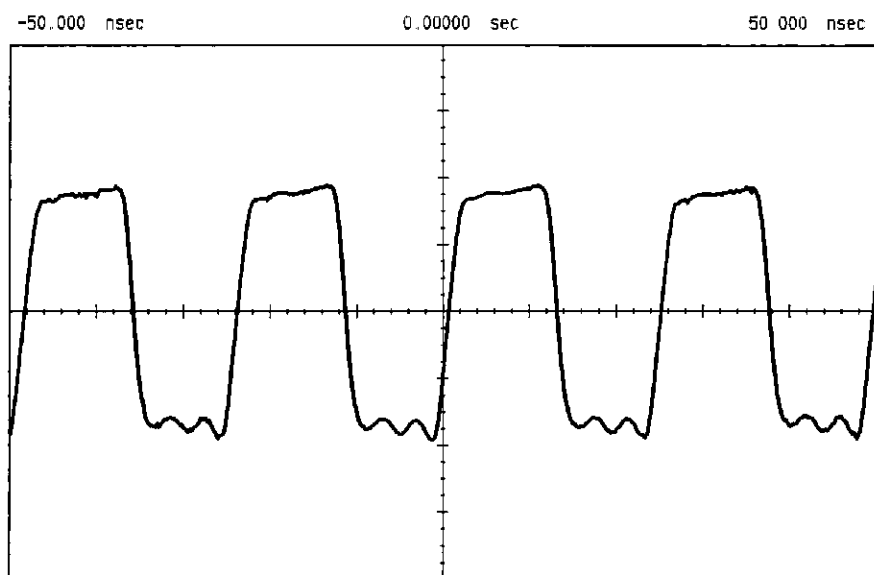

Figure 6B-8 54110D Cable Location Diagram



Ch. 1	=	200.0 mvolts/div	Offset	=	-380.0 mvolts
Timebase	=	10.0 nsec/div	Delay	=	0.00000 sec
Ch. 1 Parameters			P-P Volts	=	764.0 mvolts
Freq.	=	92.8505 MHz			

Figure 6B-9. Waveform on the A3 MCLK (Master Clock) cables.

Note

This waveform must be terminated in 50 ohms, the CAL signal must be applied to both channel 1 and 2, and the scope must be configured as shown on page 6B-18.

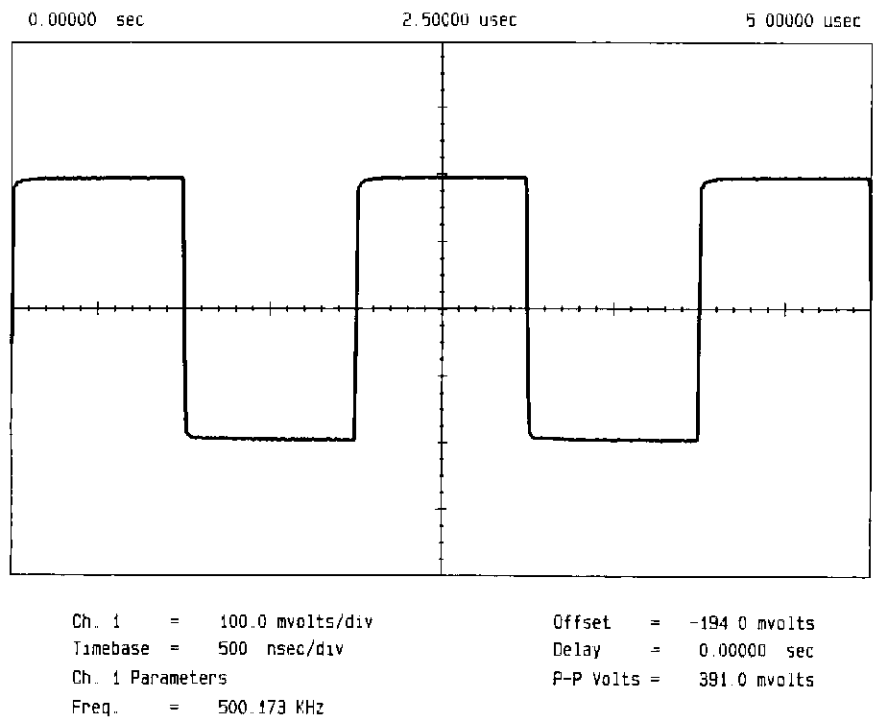

Figure 6B-10. Waveform on the A3 CAL (CAL signal) cables

Note

This waveform must be terminated in 50 ohms, the CAL signal must be applied to both channel 1 and 2, and the scope must be configured as shown on page 6B-18.

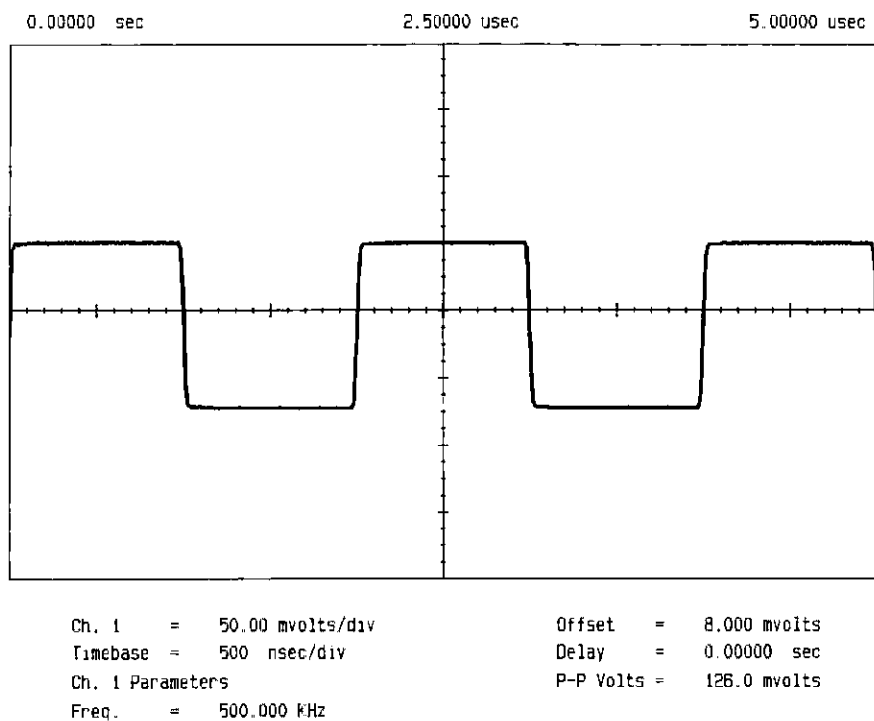
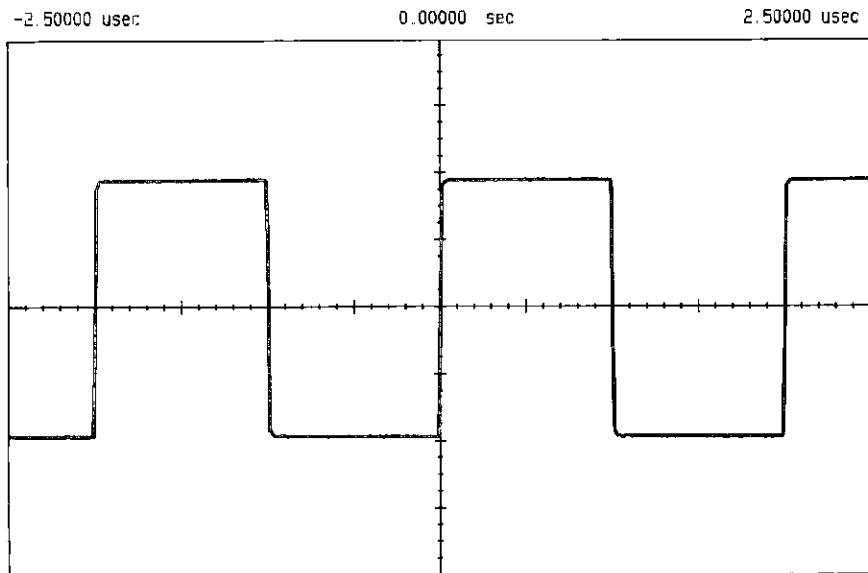

Figure 6B-11. Waveform at the A4/A6 IFout cables.

Note

This waveform must be terminated in 50 ohms, the CAL signal must be applied to both channel 1 and 2, and the scope must be configured as shown on page 6B-18.



Ch 1	=	200.0 mvolts/div	Offset	=	-380.0 mvolts
Timebase	=	500 nsec/div	Delay	=	0.00000 sec
Ch 1 Parameters			P-P Volts	=	768.0 mvolts
Freq.	=	500.173 kHz			

Figure 6B-12 Waveform at the A4/A6 TCLK (Trigger Clock) cables

Note

This waveform must be terminated in 50 ohms, the CAL signal must be applied to both channel 1 and 2, and the scope must be configured as shown on page 6B-18

Note

The trigger level must be set to -215 mV with the CAL signal applied.

6B-22. PROBE/POD TROUBLESHOOTING

The most efficient method of troubleshooting probe/pod failures is swapping the pods from one channel to another. The first step is to determine if the instrument passes self-tests which can be done with all the pods removed. Once the instrument passes self-test, the next step is to determine if one of the four probe/pods is functioning properly when an external stimulus is applied. Using the known good probe/pod in the channel suspected of having a bad pod will isolate the problem to the pod or analog portion of the instrument for that channel.

NOTE

When attempting to check the channels 3 and 4 probe/pods, they should be installed in channel 1 or 2 so that the stimulus signal can be more easily observed when the pods are working.

If a probe/pod proves to be faulty, it should be replaced with an exchange assembly or new probe/pod depending on the model (see Replaceable Parts, Section 4 of this manual)